

OWNER'S GUIDE &

INSTALLATION INSTRUCTIONS

NMEA 2000® Network or NMEA 0183 Device

Record the information found on the cable tag for future reference.

Part No. _____ Date _____

Ultrasonic Processor

for Models: UDST800, UST800, UST850

Patent <http://www.airmar.com/patent.html>

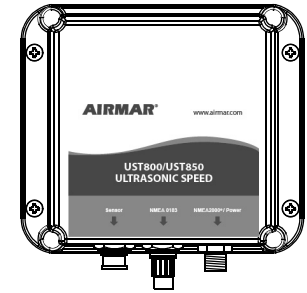
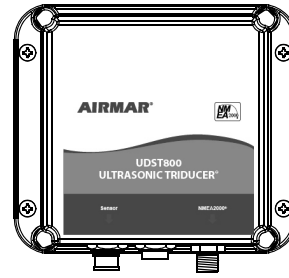

Follow the precautions below for optimal product performance and to reduce the risk of property damage, personal injury, and/or death.

WARNING: Always wear safety glasses, a dust mask, and ear protection when installing.

WARNING: The power must be OFF before proceeding.

WARNING: The power supply voltage must be 9 - 16VDC.

WARNING: A safe installation requires a 0.5 amp fast-blow fuse or circuit breaker.

CAUTION: To reduce electrical interference from other electrical wiring and any on-board equipment with strong magnetic fields such as radar equipment, radio transmitters, boat engines, generators, etc., separate the Ultrasonic Processor and cables by at least 1 m (3').

CAUTION: Never use solvents. Cleaner, fuel, sealant, paint, and other products may contain solvents that can damage plastic parts.

IMPORTANT: Read the instructions completely before proceeding with the installation. These instructions supersede any other instructions in your instrument manual if they differ.

Installation

Locating the Ultrasonic Processor

CAUTION: If the processor will be mounted on a vertical surface, face the connectors downward to avoid water seeping into the box.

1. Select a convenient, *dry*, mounting location for the water-resistant Ultrasonic Processor a minimum of 1 m (3') from other cables and electronic equipment.
2. Hold the processor at the selected location and mark the position of the four screw holes with a pencil.
3. At the marked locations, drill a 3mm or 1/8" hole to a depth of 10 mm (3/8").
4. Fasten the processor to the selected mounting surface, using the screws supplied.

Routing the Cables & Connecting

CAUTION: Do not remove connectors to ease cable routing. If the cable must be cut and spliced, use Airmar's splash-proof Junction Box No. 33-035 and follow the instructions supplied. Removing the waterproof connector or cutting the cable, except when using a watertight junction box, will void the sensor's warranty.

1. Route the cables to the Ultrasonic Processor. Be careful not to tear the cable jacket when passing it through the bulkhead(s) and other parts of the boat. Use grommets to prevent chafing. To reduce electrical interference, separate the sensor cable from other electrical wiring and the engine. *Do not fasten the cables in place at this time.*

NMEA 0183—See Figure 1 on the next page.

A power cable is needed. The DeviceNet cable, 33-565-04, supplied must be modified for use as the power cable. To modify the cable, follow the Installation Instructions supplied with the Accessory Cable, 33-1352-01.

NMEA 2000—See Figure 2 or 3 on the next page.

2. Connect the cables to the Ultrasonic Processor.

NMEA 0183—Connect the power cable to the power supply. Follow the color code on the flag label attached to the cable.

3. Fasten all the cables in place. Coil any excess cable and secure it with cable-ties to prevent damage.

Applications

Connect to an NMEA 2000 network or an NMEA 0183 device.

Tools & Materials

Safety glasses

Dust mask

Ear protection

Pencil

Electric drill

Drill bit 3mm or 1/8"

Phillips screwdriver

Accessory cable 33-1352-01 (power cable for NMEA 0183 device)

Grommet(s) (some installations)

Cable ties

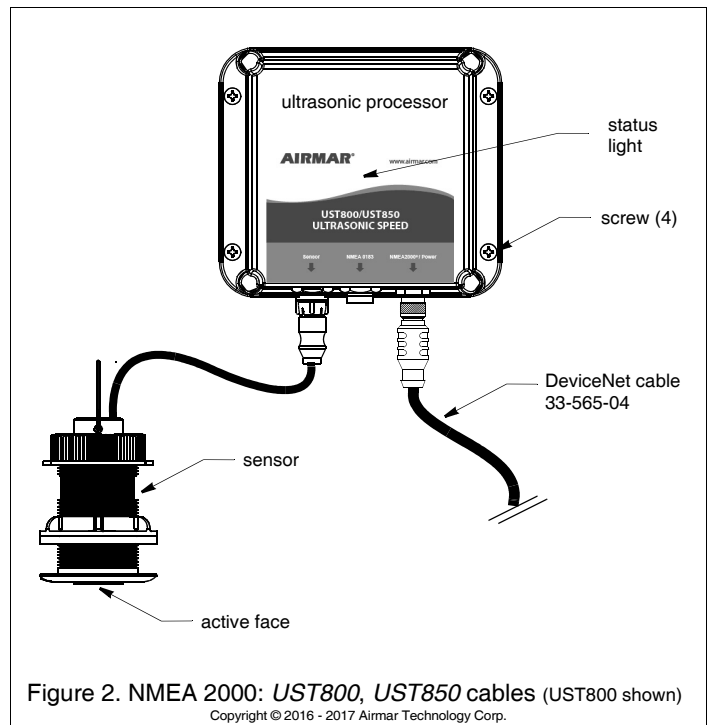
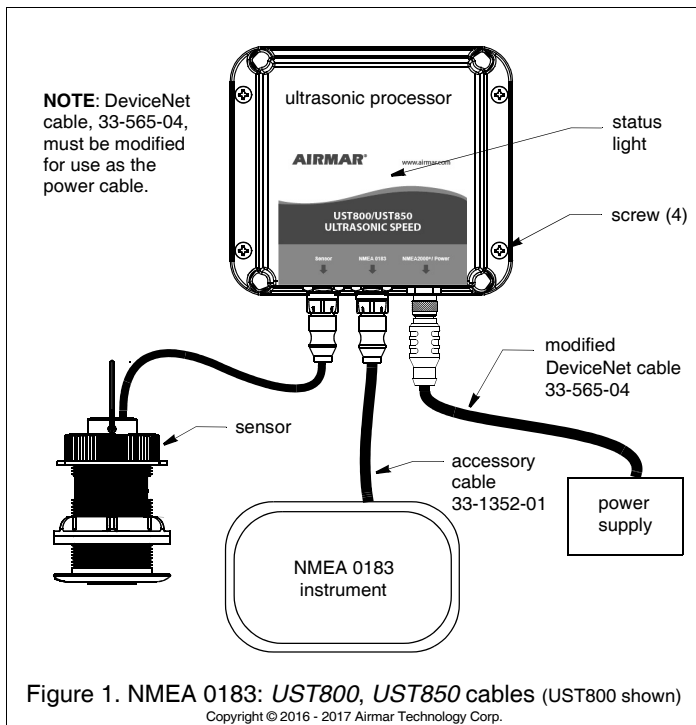

Operation

Apply power to the Ultrasonic Processor.

UST800, UST850: Status Lights

- Yellow Initializing and testing
- Green Pass
- Red Fail

Troubleshooting

No Readings

- Is the ultrasonic insert installed in the housing and connected to the Ultrasonic Processor?
- Is power being supplied to the Ultrasonic Processor? The power must be within the correct voltage range. At a voltage lower than 9VDC, performance is degraded and the unit will shut down.
- Is the ultrasonic insert oriented with the arrow on the top pointing forward toward the bow? If the insert cannot be seated in the housing with the arrow pointing forward, check that the arrow on the flange of the housing is pointing forward. If this is not the case, the housing needs to be reinstalled with the proper orientation.

Inaccurate Speed Readings

- If the ultrasonic speed sensor is 'ON' when the boat is stationary, you may see a speed readout of a fraction of a knot because of water movement under the hull.
- If the speed reading is consistently the same percentage higher or lower than the true speed, the speed function within the instrument needs to be re-calibrated. Follow the instructions in your instrument owner's manual.

Inaccurate Depth Readings or Inaccurate Speed Readings Above 10knots

- The sensor is installed in turbulent water. The cause may be water intake or discharge openings, strakes, fittings, hull irregularities upstream of the sensor, or the shape of the hull in that area. The sensor must be reinstalled in another location.
- The ultrasonic insert is covered with aquatic growth. Clean the active face of the sensor with a dull putty knife, being careful to

avoid scratching the surface (Figure 2). If fouling is severe, lightly wet sand the active face with fine grade (#320) wet/dry paper.

- Aerated water is flowing under the sensor because the boat is designed to pull air under the hull. The sensor will not work on this type of boat.

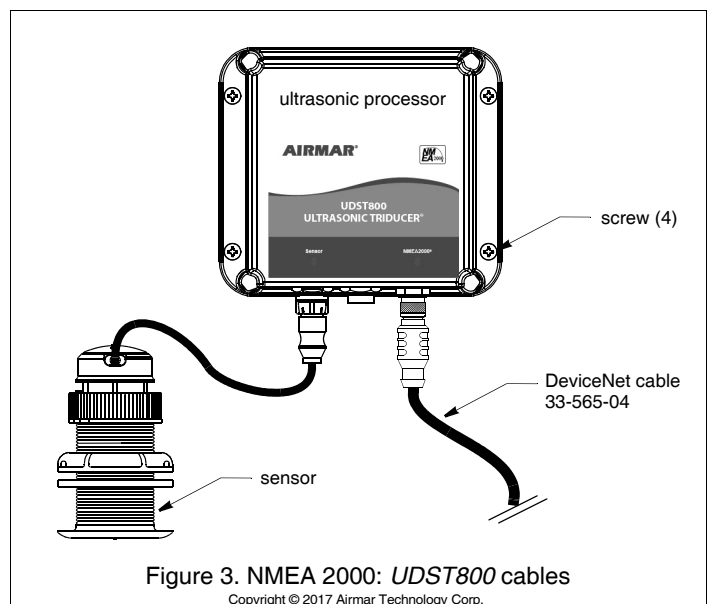

Replacement Parts

The information needed to order a replacement part is printed on the unit and cable tags. Do not remove tags. When ordering, specify the part number and date. For convenient reference, record this information on the top of page one.

To connect to an NMEA 0183 device purchase Accessory Cable 33-1352-01 and follow the Installation Supplement supplied.

Obtain parts from your instrument manufacturer or marine dealer.

Gemeco

USA

Tel: 803-693-0777

email: sales@gemeco.com

Airmar EMEA

Europe, Middle East, Africa

Tel: +33.(0)2.23.52.06.48

email: sales@airmar-emea.com



35 Meadowbrook Drive, Milford, New Hampshire 03055-4613, USA
• www.airmar.com

Copyright © 2016 - 2018 Airmar Technology Corp. All rights reserved.

OWNER'S GUIDE & INSTALLATION INSTRUCTIONS

Thru-Hull: *Retractable with Valve*

Ultrasonic Speed & Temperature Smart™ Sensor

Models: **UST800, UST850**

07/24/18

17-572-01 rev.03

Follow the precautions below for optimal product performance and to reduce the risk of property damage, personal injury, and/or death.

WARNING: Always wear safety glasses, a dust mask, and ear protection when installing.

WARNING: The valve is not a watertight seal! Always install the ultrasonic insert or the blanking plug secured with the (UST850 insert nut) cap nut and safety wire for a watertight seal.

WARNING: UST850—The ultrasonic insert or the blanking plug must be installed in a housing with a valve. When the valve assembly is removed, always install the *short emergency plug* secured with the cap nut and safety wire for a watertight seal.

WARNING: The o-rings must be intact and well lubricated to make a watertight seal.

WARNING: Always attach the safety wire to prevent the ultrasonic insert or blanking plug from backing out in the unlikely event that the cap nut fails or is screwed on incorrectly.

WARNING: Immediately check for leaks when the boat is placed in the water. Do not leave the boat unchecked for more than three hours. Even a small leak may allow considerable water to accumulate.

CAUTION: Never pull, carry, or hold the sensor by its cable; this may sever internal connections.

CAUTION: Plastic housing—Never use a fairing with a plastic housing. The protruding sensor would be vulnerable to damage from impact.

CAUTION: Metal housing—Never install a metal housing on a vessel with a positive ground system.

CAUTION: The arrow on the top of the ultrasonic insert must point forward toward the bow to align with the water flow.

CAUTION: The bottom of the ultrasonic insert must be flush with the bottom of the housing.

CAUTION: The sensor must be in good contact with the water at all times.

CAUTION: Never use solvents. Cleaner, fuel, sealant, paint, and other products may contain solvents that can damage plastic parts, especially the sensor's active face.

IMPORTANT: Read the instructions completely before proceeding with the installation. These instructions supersede any other instructions in your instrument manual if they differ.

Record the information found on the cable tag for future reference.

Part No. _____ Date _____

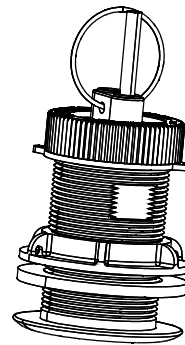

UST800
B120, P120
housing

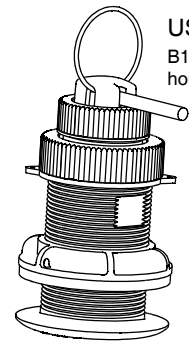

UST850
B17, P17
housing

Patent <http://www.airmar.com/patent.html>

Applications

- Not recommended for boats designed to pull air under the hull.
- **Plastic housing** recommended for fiberglass or metal hull only. *Never install a plastic housing in a wood hull since swelling of the wood may fracture the plastic.*
- **Bronze housing** recommended for fiberglass or wood hull only. *Never install a bronze housing in a metal hull because electrolytic corrosion will occur.*
- UST800 with plastic housing recommended for an aluminum hull less than 6mm (1/4") thick.

How the Ultrasonic Speed Sensor Works

The speed sensor uses ultrasonic pulses to collect echoes from small particles in the water as they pass under two transducers embedded in the insert (Figure 1). These transducers monitor the particles in their respective beams. As the boat travels through the water, both transducers 'view' the same stream of particles. Because it takes time for particles to travel between the two transducers, the aft transducer detects the particles later than does the fore transducer. By measuring this time lapse, the instrument calculates the boat speed. If the boat is airborne, even for a short time, or in highly aerated water, the sensor will measure an incorrect speed.

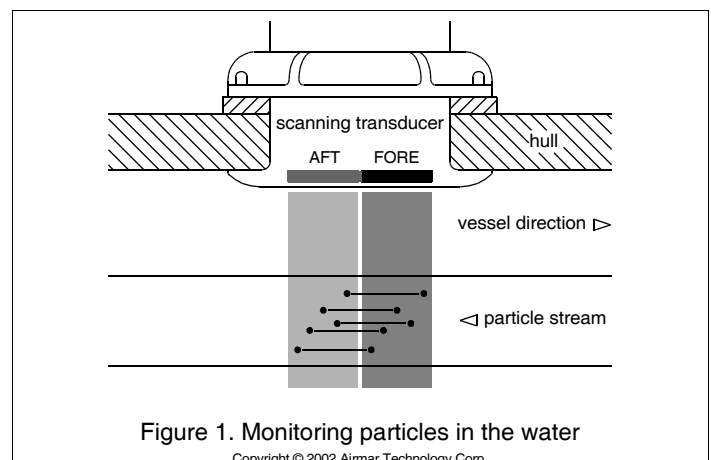

Figure 1. Monitoring particles in the water

Copyright © 2002 Airmar Technology Corp.

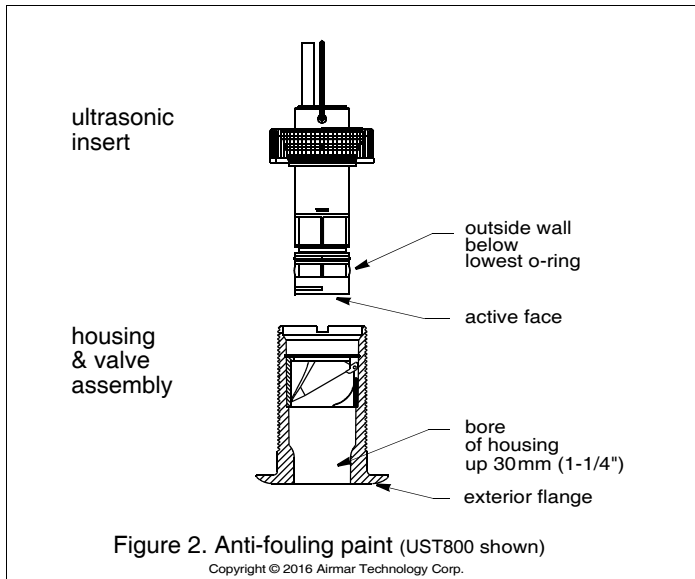

Figure 2. Anti-fouling paint (UST800 shown)
Copyright © 2016 Airmar Technology Corp.

Tools & Materials

- Safety glasses
- Dust mask
- Ear protection
- Water-based anti-fouling paint (**mandatory in salt water**)
- Electric drill with 10mm or larger chuck capacity
- Drill bit 3mm or 1/8"
- Hole saw 51 mm or 2"
- Sandpaper
- Mild household detergent *or* weak solvent (such as alcohol)
- File (installation in a metal hull)
- Marine sealant (suitable for below waterline)
- Slip-joint pliers (installing a metal housing)
- Installation in a cored fiberglass hull (see page 6):
 - Hole saw for hull interior 60mm or 2-3/8"
 - Fiberglass cloth and resin
 - or* Cylinder, wax, tape, and casting epoxy

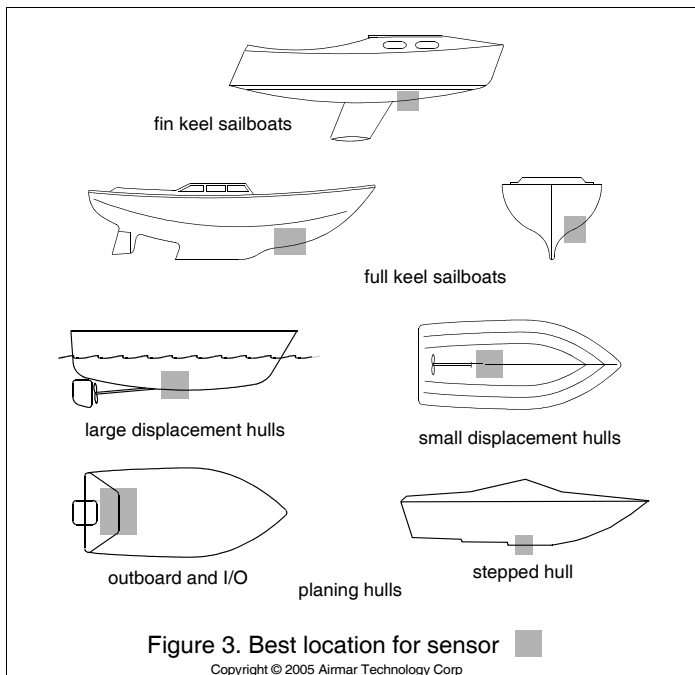

Figure 3. Best location for sensor
Copyright © 2005 Airmar Technology Corp.

Anti-fouling Paint

Surfaces exposed to salt water must be coated with anti-fouling paint. *Use water-based anti-fouling paint only.* Never use ketone-based paint, since ketones can attack many plastics possibly damaging the sensor.

It is easier to apply anti-fouling paint before installing the sensor, but allow sufficient drying time. Reapply paint every 6 months or at the beginning of each boating season. Paint the following surfaces (Figure 3):

- Outside wall of the ultrasonic insert below lowest o-ring
- Active face of the ultrasonic insert
- Exterior flange of housing
- Bore of housing up 30mm (1-1/4")
- Blanking plug below lower o-ring including exposed end

Mounting Location

CAUTION: Do not mount the sensor in line with or near water intake or discharge openings or behind strakes, fittings, or hull irregularities that will disturb the water flow.

CAUTION: Do not mount the sensor directly ahead of a depth transducer, since turbulence generated by the housing will adversely affect the depth transducer's performance, especially at high speeds. Mount side-by-side.

- The sensor must be continuously immersed in water.
- The water flowing under the sensor must be smooth with a minimum of bubbles and turbulence (especially at high speeds).
- Choose an accessible spot inside the vessel with adequate space for the height of the housing, tightening the nuts, and installing the ultrasonic insert. Allow a minimum of 280mm (11").

Boat Types (Figure 2)

- **Fin keel sailboats**—Mount on or near the centerline and forward of the fin keel 300–600mm (1–2').
- **Full keel sailboats**—Locate amidships and away from the keel at the point of minimum deadrise.
- **Displacement hull powerboats**—Locate amidships near the centerline.
- **Planing hull powerboats**—Mount well aft to ensure the sensor is in contact with the water at high speeds.

Installation

Hole Drilling

Cored fiberglass hull—Follow separate instructions on page 6.

1. Drill a 3mm or 1/8" pilot hole from inside the hull. If there is a rib, strut, or other hull irregularity near the selected mounting location, drill from the outside.
 2. Using a 51 mm or 2" hole saw, cut the hole perpendicular to the hull from outside the hull.
 3. Sand and clean the area around the hole, inside and outside, to ensure that the sealant will adhere properly to the hull. If there is any petroleum residue inside the hull, remove it with either mild household detergent or a weak solvent (alcohol) before sanding.
- Metal hull**—Remove all burrs with a file and sandpaper.

Bedding

CAUTION: Be sure the surfaces to be bedded are clean and dry.

Apply a 2mm (1/16") thick layer of marine sealant around the flange of the housing that contacts the hull and up the sidewalls of the housing (Figure 4 or 5). *The sealant must extend 6mm (1/4") higher than the combined thickness of the hull, washer, and hull nut.* This will ensure there is sealant in the threads to seal the hull and to hold the hull nut securely in place.

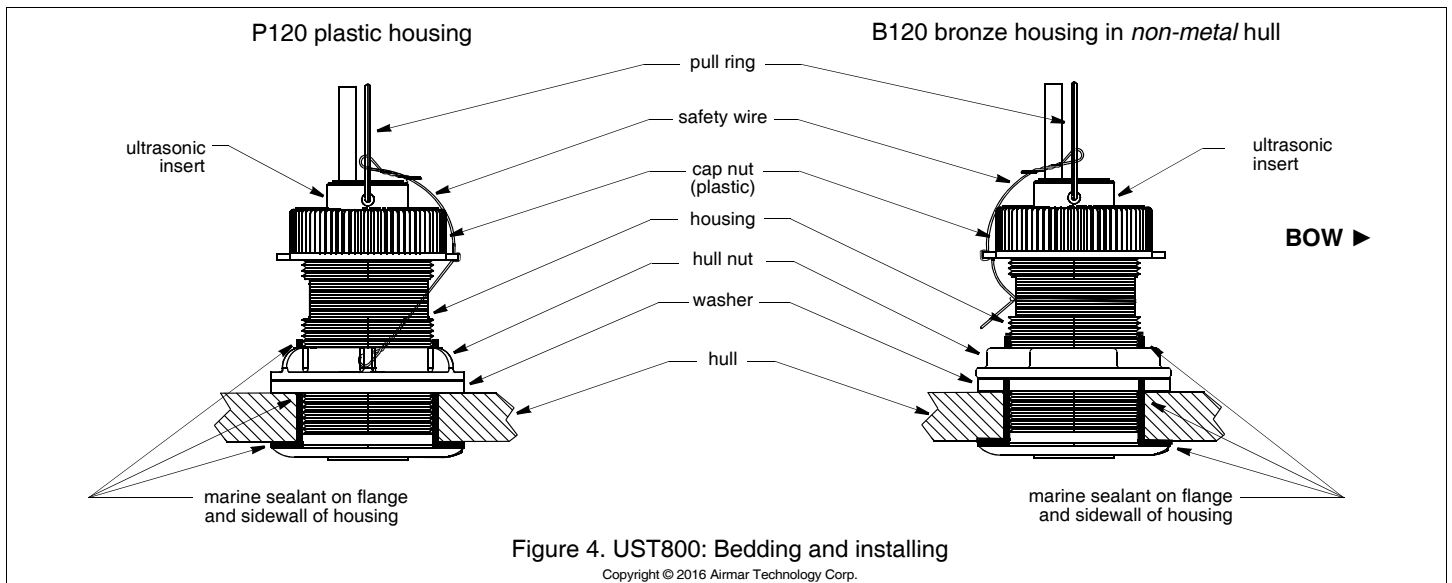

Figure 4. UST800: Bedding and installing

Copyright © 2016 Airmar Technology Corp.

Installing

CAUTION: The arrow on the flange of the housing must point forward toward the bow, so the ultrasonic insert will be aligned with the water flow.

1. From outside the hull, push the housing into the mounting hole using a twisting motion to squeeze out excess sealant (Figure 4 or 5). *Align the arrow on the flange of the housing pointing forward toward the bow.* If the sensor is not installed on the centerline, angle the housing slightly toward the centerline to align it with the water flow.
2. From inside the hull, slide the washer onto the housing.
3. Screw the hull nut in place. Be sure the notch on the upper rim of the housing and the corresponding arrow on the flange are still positioned forward toward the bow.

Plastic housing—Do not clamp tightly on the wrench flats, causing the housing to fracture.

Plastic hull nut—**Hand tighten** only. Do not over tighten.

Metal hull nut—Tighten with slip-joint pliers.

Cored fiberglass hull—Do not over tighten, crushing the hull.

Wood hull—Allow the wood to swell before tightening the hull nut.

4. Remove any excess marine sealant on the outside of the hull to ensure smooth water flow under the sensor.

5. The o-rings must be intact and well lubricated to make a watertight seal. After the marine sealant cures, inspect the o-rings on the ultrasonic insert (replace if necessary) and lubricate them with the silicone lubricant supplied (Figure 6 or 7).

UST850—Also inspect the o-rings on the valve assembly (replace if necessary) and lubricate them with the silicone lubricant supplied. Slide the valve assembly into the housing. *Seat it into place with a pushing twisting motion until the key fits into the notch.* Screw the **cap nut** in place. **Hand tighten** only. Do not over tighten.

6. The ultrasonic insert must be fully inserted into the housing and the nut(s) screwed on completely to make a watertight seal. *Be sure the bottom of the ultrasonic insert is flush with the bottom of the housing.*

UST800—Attach the pull ring. Slide the ultrasonic insert into the housing with the arrow on the top pointing forward toward the bow. Seat it into place with a pushing twisting motion until the key fits into the notch. *The arrow on the top of the ultrasonic insert, the notch, and the arrow on the flange of the housing will all be aligned.* Be careful not to rotate the housing and disturb the sealant. Screw the cap nut in place and **hand tighten** only. Do not over tighten.

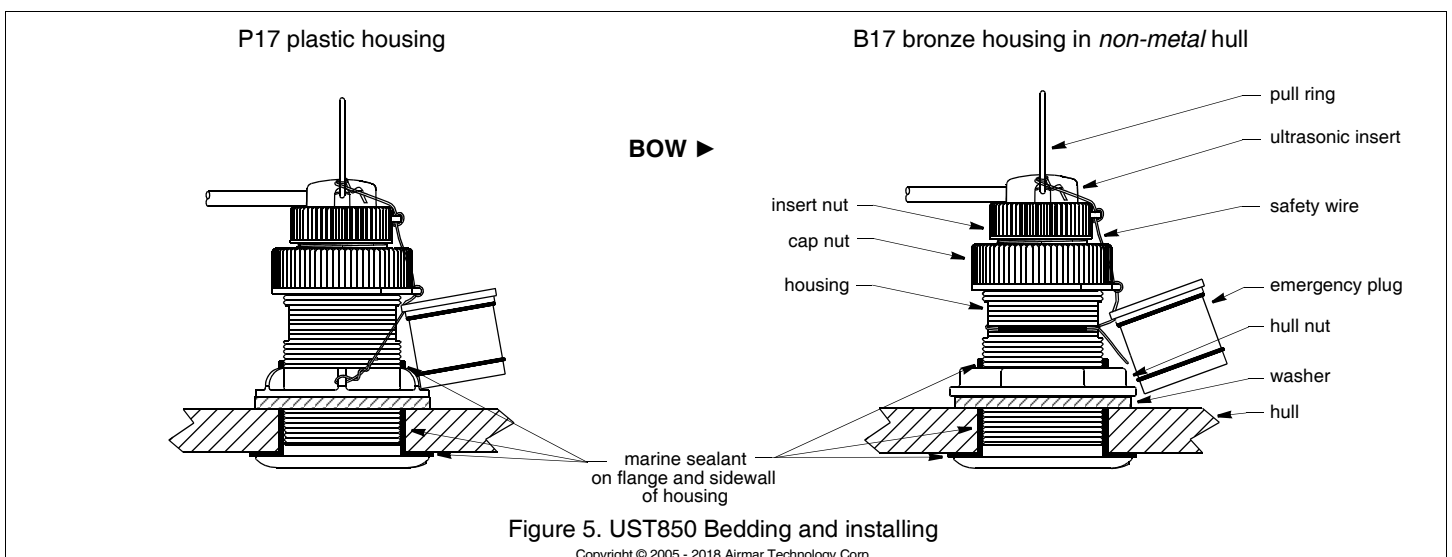

Figure 5. UST850 Bedding and installing

Copyright © 2005 - 2018 Airmar Technology Corp.

UST850—Slide the *insert* nut along the cable until it rests on the top of the ultrasonic insert. Attach the pull ring to the ultrasonic insert, capturing the *insert* nut. Slide the ultrasonic insert into the housing assembly. Seat it into place with a pushing twisting motion until the key fits into the notch. *The arrow on the top of the ultrasonic insert, the notch in the housing, and the arrow on the flange will be aligned.* Being careful not to rotate the housing and disturb the sealant, screw the *insert* nut in place. **Hand tighten** only. Do not over tighten.

7. Always attach the safety wire to prevent the ultrasonic insert from backing out in the unlikely event that the cap/insert nut fails or is screwed on incorrectly.

UST800 (Figure 4)

Plastic housing—Attach the safety wire to one eye in the hull nut. Keeping the wire taut throughout, lead the wire in a counterclockwise direction and thread it through one eye in the cap nut. Thread the wire through the eye a second time. Loop the wire through the pull ring. Twist the wire securely to itself.

Metal housing—Wrap one end of the safety wire tightly around the housing and twist it together with the long end. Keeping the wire taut throughout, lead the wire straight up and through the eye in the cap nut. Thread the wire through the eye a second time. Loop the wire through the pull ring. Twist the wire securely to itself.

UST850 (Figure 5)

Plastic housing—Attach the safety wire securely to one eye in the *hull* nut. Thread the *short emergency plug* onto the wire. Keeping the wire taut throughout, lead the wire in a counterclockwise direction and thread it through one eye in the *cap* nut. Thread the wire through the eye a second time. Then lead the wire in a counterclockwise direction and thread it through the eye in the *insert* nut. Thread the wire through the eye a second time. Loop the wire through the pull ring. Twist the wire securely to itself.

Metal housing—Wrap one end of the safety wire tightly around the housing and twist it together with the long end. Thread the *short emergency plug* onto the wire. Keeping the wire taut throughout, lead the wire straight up and through one eye in the *cap* nut. Thread the wire through the eye a second time. Lead the wire in a counterclockwise direction and thread it through the eye in the *insert* nut. Thread the wire through the eye a second time. Loop the wire through the pull ring. Twist the wire securely to itself.

Cable Routing & Connecting

Follow the instructions supplied with the Echo Correlation Processor.

Checking for Leaks

When the boat is placed in the water, **immediately** check around the sensor for leaks. Note that very small leaks may not be readily observed. *Do not to leave the boat in the water unchecked for more than 3 hours.* If there is a small leak, there may be considerable bilge water accumulation after 24 hours. If a leak is observed, repeat “Bedding” and “Installing” **immediately** (page 2).

Operation, Maintenance & Repair

How the Valve Works

The valve is not a watertight seal! The sensor incorporates a self-closing valve which minimizes the flow of water into the vessel when the ultrasonic insert is removed. The curved flap valve is activated by both a spring and water pressure. Water pushes the flap valve upward to block the opening, so there is no gush of water into the boat. *Always install the ultrasonic insert or the blanking plug secured with the (UST850 insert nut) cap nut and safety wire for a watertight seal.*

Using the Blanking Plug

To protect the ultrasonic insert, use the blanking plug when:

- The boat will be kept in salt water for more than a week.
- The boat will be removed from the water.
- Aquatic growth build-up is suspected due to inaccurate readings from the instrument.

The o-rings must be intact and well lubricated to make a watertight seal. Inspect the o-rings (replace if necessary) and lubricate them with the silicone lubricant supplied or petroleum jelly (Figure 6 or 7).

UST800

1. Remove the ultrasonic insert from the housing by removing the safety wire from the pull ring and the cap nut. Unscrew the cap nut (Figure 4).

2. Grasp the pull ring and remove the ultrasonic insert with a slow pulling motion (Figure 6).

NOTE: *In the unlikely event that the ultrasonic insert cannot be removed, see “Servicing the Valve Assembly” on page 5.*

3. Slide the blanking plug into the housing (Figure 6). Seat it into place with a pushing twisting motion until the key fits into the notch. Screw the cap nut in place. **Hand tighten** only. Do not over tighten.

4. Reattach the safety wire to prevent the blanking plug from backing out in the unlikely event that the cap nut fails or is screwed on incorrectly (Figure 4).

UST850

1. Place the *insert* nut on the top of the blanking plug (Figure 7). Attach the pull ring to the plug, capturing the *insert* nut.

2. Remove the ultrasonic insert from the housing by removing the safety wire from the pull ring and the *insert* nut (Figure 5).

3. Unscrew the *insert* nut. **Do not remove the cap nut.** Grasp the pull ring and remove the ultrasonic insert with a slow pulling motion (Figure 7).

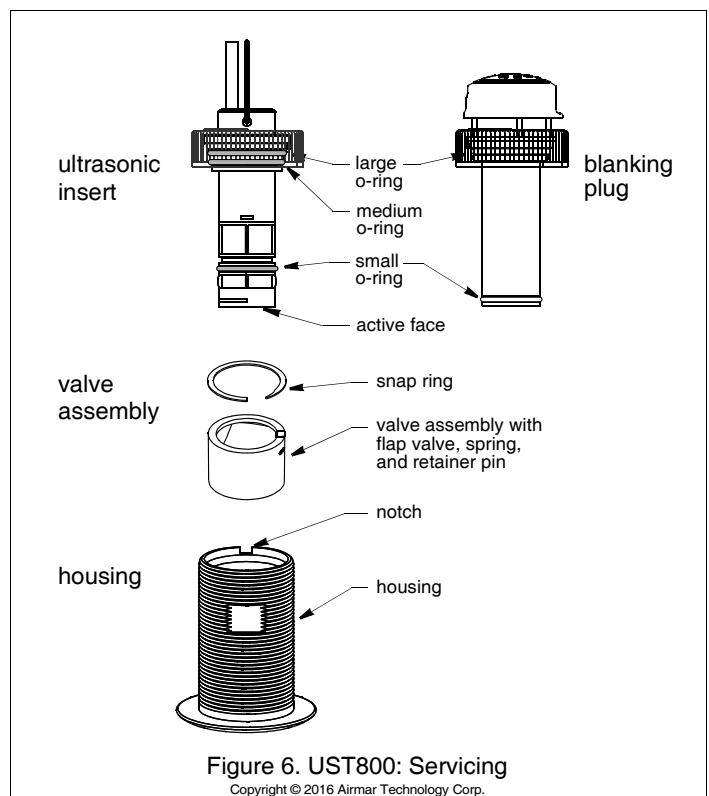

Figure 6. UST800: Servicing

Copyright © 2016 Airmar Technology Corp.

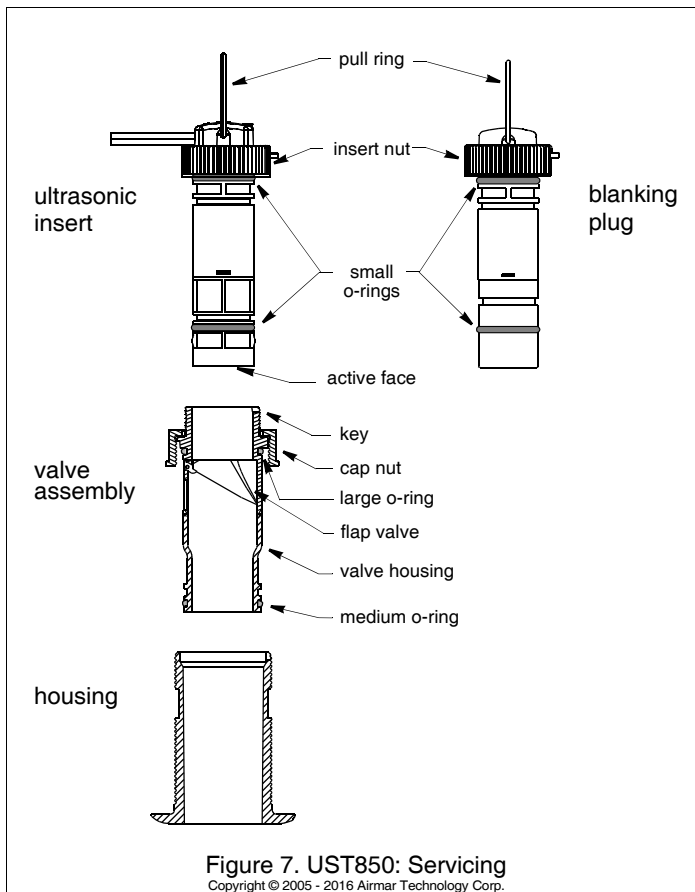

Figure 7. UST850: Servicing
Copyright © 2005 - 2016 Airmar Technology Corp.

NOTE: In the unlikely event that the ultrasonic insert cannot be removed, see “UST850: Servicing the Valve Assembly” on page 5.

4. Slide the blanking plug into the housing. Seat it into place with a pushing twisting motion until the key fits into the notch. Screw the *insert* nut into place and **hand tighten** only. Do not over tighten. Note that the plug must be fully inserted into the housing and the *insert* nut screwed on completely to make a watertight seal.
5. Reattach the safety wire to prevent the blanking plug from backing out in the unlikely event that the insert/cap nut fails or is screwed on incorrectly (Figure 5).

Servicing the Ultrasonic Insert

CAUTION: The active face of the ultrasonic insert is easily damaged. Do not scratch, gouge, or sand it with coarse sandpaper.

Aquatic growth will seriously affect the performance of the ultrasonic insert. Clean the active face with a dull putty knife, being careful to avoid scratching the surface (Figure 6 or 7). If fouling is severe, lightly wet sand the active face with fine grade (#320) wet/dry paper.

O-rings must be free of abrasions and cuts to ensure a watertight seal. Install the o-rings on the ultrasonic insert as shown (Figure 6 or 7). The remaining o-rings are placed in similar positions on the blanking plug.

Servicing the Valve Assembly

UST800

Should the valve fail, remove it for servicing. A replacement O-ring and Valve Kit is available.

1. The o-rings must be intact and well lubricated to make a watertight seal. On the blanking plug, inspect (replace if necessary) and lubricate the o-rings with silicone lubricant or petroleum jelly (Figure 6).

2. Remove the ultrasonic insert from the housing (Figure 4).
3. Remove the snap ring from the valve assembly using a screwdriver to pry the end of the ring free (Figure 6).
4. Slide the valve assembly upward and out of the housing slowly.

NOTE: The flap valve retainer pin is a loose slip-fit and may slide out when the assembly is removed.
5. Slide the blanking plug into the housing. Seat it into place with a pushing twisting motion until the key fits into the notch in the housing. **Hand tighten** the cap nut. Do not over tighten. Reattach the safety wire (Figure 4).
6. Clean, repair, or replace the valve assembly so the flap valve moves freely and seats against the valve housing (Figure 6).
7. To reinstall the valve assembly, remove the blanking plug. Slide the valve assembly into the housing with the flap valve pointing downward. Insert the snap ring being certain that it **locks into the groove** in the housing wall.
8. Slide the ultrasonic insert/blanking plug into the housing with the arrow on the top pointing forward toward the bow. Rotate the ultrasonic insert/blanking plug until the key fits into the notch in the housing. **Hand tightening** the cap nut. Do not over-tighten.
9. Reattach the safety wire to prevent the ultrasonic insert/blanking plug from backing out in the unlikely event that the cap nut fails or is screwed on incorrectly (Figure 4).

UST850

WARNING: If the ultrasonic insert/blanking plug is caught in the valve assembly trapping the *cap nut*, **temporarily** hold the *short emergency plug* in place with the safety wire. Then, separate the ultrasonic insert/blanking plug from the valve assembly. If they cannot be separated and the sensor must be left unattended, remove the pull ring, unscrew the *insert* nut, and unscrew the *cap nut*. Cut the cable a minimum of 1 m (3') from the ultrasonic insert to free the *cap nut*. Later, splice the cable using Airmar’s splash-proof Junction Box No. 33-035.

Should the valve fail, remove it for servicing. A replacement O-ring and Valve Kit is available. When the valve assembly is removed, always install the *short emergency plug* secured with the *cap nut* and safety wire for a watertight seal.

1. Remove the *short emergency plug* from the safety wire (Figure 5).
2. The o-ring must be intact and well lubricated to make a watertight seal. Inspect the o-ring (replace if necessary) and lubricate it with silicone lubricant or petroleum jelly.
3. Unscrew the *cap nut*. With the *short emergency plug* ready in one hand, remove the ultrasonic insert/blanking plug and valve assembly as one unit by pulling upward on the pull ring. Rapidly install the *short emergency plug* to minimize the flow of water into the boat.

NOTE: The *short emergency plug* is not secure until the *CAP nut* is in place.
4. To free the *cap nut*, remove the ultrasonic insert/blanking plug from the valve assembly by unscrewing the *insert* nut (Figure 7). Grasp the ultrasonic insert/blanking plug by the pull ring and pull upward slowly.
5. Secure the *short emergency plug* with the *cap nut*. **Hand tighten** only. Do not over tighten. Reattach the safety wire (Figure 5).
6. Clean, repair, or replace the valve assembly, so the flap valve moves freely and seats against the valve housing (Figure 7).
7. The o-rings must be intact and well lubricated to form a watertight seal. To reinstall the valve assembly and ultrasonic insert/blanking plug, inspect (replace if necessary) and lubricate all of the o-rings with silicone lubricant or petroleum jelly.

8. Remove the safety wire from the *cap* nut and unscrew it. With the valve assembly ready in one hand, remove the *short emergency plug*. Rapidly slide the valve assembly into the housing. Seat it into place with a pushing twisting motion until the key fits into the notch. Screw the *cap* nut in place **hand tighten** only. Do not over tighten.
9. Reinstall the ultrasonic insert/blanking plug. Be sure the ultrasonic insert/blanking plug has the arrow on the top pointing forward toward the bow. Seat it into place with a pushing twisting motion until the key fits into the notch. Screw the *insert* nut in place and **hand tighten** only. Do not over tighten.
10. Attach the safety wire to the *short emergency plug*, the *cap* nut, the *insert* nut, and the pull ring to prevent the ultrasonic insert/blanking plug from backing out in the unlikely event that the *insert* nut and/or *cap* nut fails or is screwed on incorrectly (Figure 5).

Winterizing

After the boat has been hauled for winter storage, remove the blanking plug to let the water drain away before reinserting it. This will prevent any water from freezing around the blanking plug and possibly cracking it.

Installation in a Cored Fiberglass Hull

The core (wood or foam) must be cut and sealed carefully. The core must be protected from water seepage and the hull must be reinforced to prevent it from crushing under the hull nut, allowing the housing to become loose.

CAUTION: Completely seal the hull to prevent water seepage into the core.

1. Drill a 3mm or 1/8" pilot hole from inside the hull. If there is a rib, strut, or other hull irregularity near the selected mounting location, drill from the outside. (If the hole is drilled in the wrong location, drill a second hole in a better location. Apply masking tape to the outside of the hull over the incorrect hole and fill it with epoxy.)
2. Using a 51 mm or 2" hole saw, cut the hole from outside the hull through the *outer* skin only (Figure 8).
3. From inside the hull, use a 60mm or 2-3/8" hole saw to cut through the *inner* skin and most of the core. The core material can be very soft. Apply only light pressure to the hole saw after cutting through the inner skin to avoid accidentally cutting the *outer* skin.
4. Remove the plug of core material so the *inside* of the outer skin and the inner core of the hull are fully exposed. Sand and clean the inner skin, core, and the outer skin around the hole.
5. If you are skilled with fiberglass, saturate a layer of fiberglass cloth with a suitable resin and lay it inside the hole to seal and strengthen the core. Add layers until the hole is the correct diameter.
Alternatively, a hollow or solid cylinder of the correct diameter can be coated with wax and taped in place. Fill the gap between the cylinder and hull with casting epoxy. After the epoxy has set, remove the cylinder.
6. Sand and clean the area around the hole, inside and outside, to ensure that the sealant will adhere properly to the hull. If there is any petroleum residue inside the hull, remove it with either mild household detergent or a weak solvent (alcohol) before sanding.
7. Proceed with "Bedding" and "Installing" (page 3).

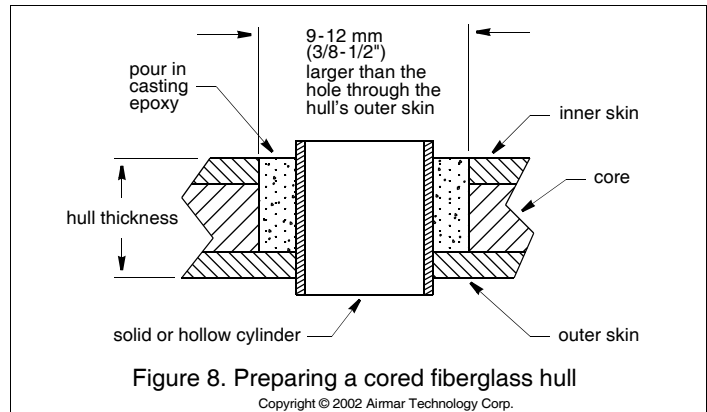

Replacement Sensor & Parts

The information needed to order a replacement Airmar sensor is printed on the cable tag. Do not remove this tag. When ordering, specify the part number and date. For convenient reference, record this information on the top of page one.

If you have purchased a plastic housing and have a wood hull or desire greater strength, purchase a metal housing. Lost, broken, and worn parts should be replaced immediately. Obtain parts from your instrument manufacturer or marine dealer.

Gemeco

USA

Tel: 803-693-0777

email: sales@gemeco.com

Airmar EMEA

Europe, Middle East, Africa

Tel: +33.(0)2.23.52.06.48

email: sales@airmar-emea.com



35 Meadowbrook Drive, Milford, New Hampshire 03055-4613, USA
•www.airmar.com