

715 Battery Distribution Cluster

IMPORTANT

Do not use any type of corrosion inhibiting spray such as CRC, INOX etc. on any part of this unit.

These units are hermetically sealed so do not require any other form of sealing.

The studs have been tinned to inhibit corrosion however a petroleum grease may be used (on metal parts only) if required.

Please note that this product is water resistant but is NOT designed to be submerged.

DUAL BATTERY CHARGING MADE EASY! The 715 battery distribution cluster is the optimum battery management system for your single engined boat.

The 715 combines 3 of BEP's 701 battery switches.

The 701 Battery Master Switch offers a number of unique features. The highlights being the contour lock system, allowing it to be locked together with other switches. The 701 also features a control knob which cannot be removed whilst in the On or Off position, however can be removed by switching to an anti-clockwise 45° position.

The 701 also features a removable rear cover insulating the rear terminals against any short circuits and ensures the switch meets ABYC requirements.

701 specifications

| | |
|------------------------|---------------------|
| Continuous rating: | 275 Amps DC |
| Intermittent rating: | 455 Amps DC |
| Cranking rating: | 1250 Amps DC |
| Voltage rating: | 48 Volts DC |
| Operation: | On / Off |
| Mounting: | recessed or surface |
| Termination stud size: | 2 x 3/8" (10mm) |

BEP Marine Battery Switch Test Procedure (UL 1107)

Continuous (1 hour)

Intermittent (5 minutes)

Cranking (10 seconds)

The test is to determine the maximum current the switch can handle for the stated time, without the terminals exceeding 212°F (100°C) above the ambient temperature.

The continuous and intermittent ratings are tested 110% of specified ratings.

Alternator Vs Battery capacity

| <u>Alternator Size</u> | <u>Second battery size</u> |
|-------------------------------|-----------------------------------|
| 10 Amp | 60 Amp hours |
| 16 Amp | 85 Amp hours |
| 25-35 Amp | 85-105 Amp hours |
| 50-60 Amp | 130-210 Amp hours |
| 80-90 Amp | 130-220 Amp hours |

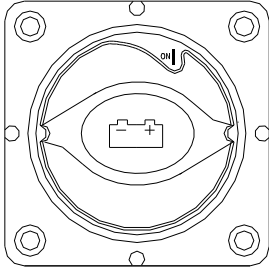

SWITCH IN ON POSITION

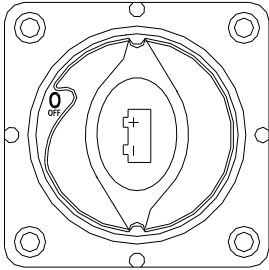

SWITCH IN OFF POSITION

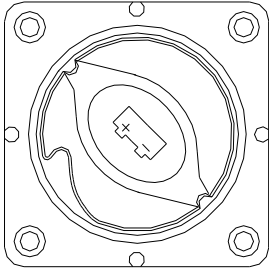

SWITCH IN REMOVAL POSITION

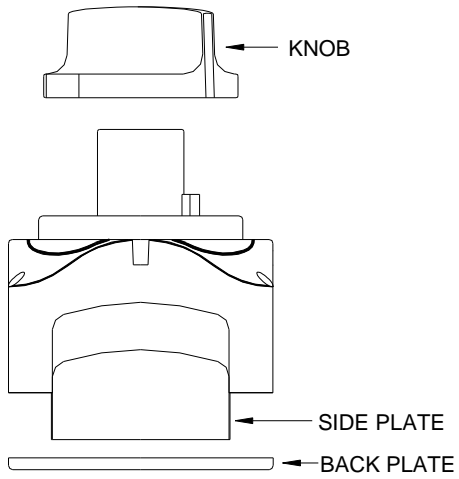

715V INSTALLATION DIAGRAM OUTBOARD

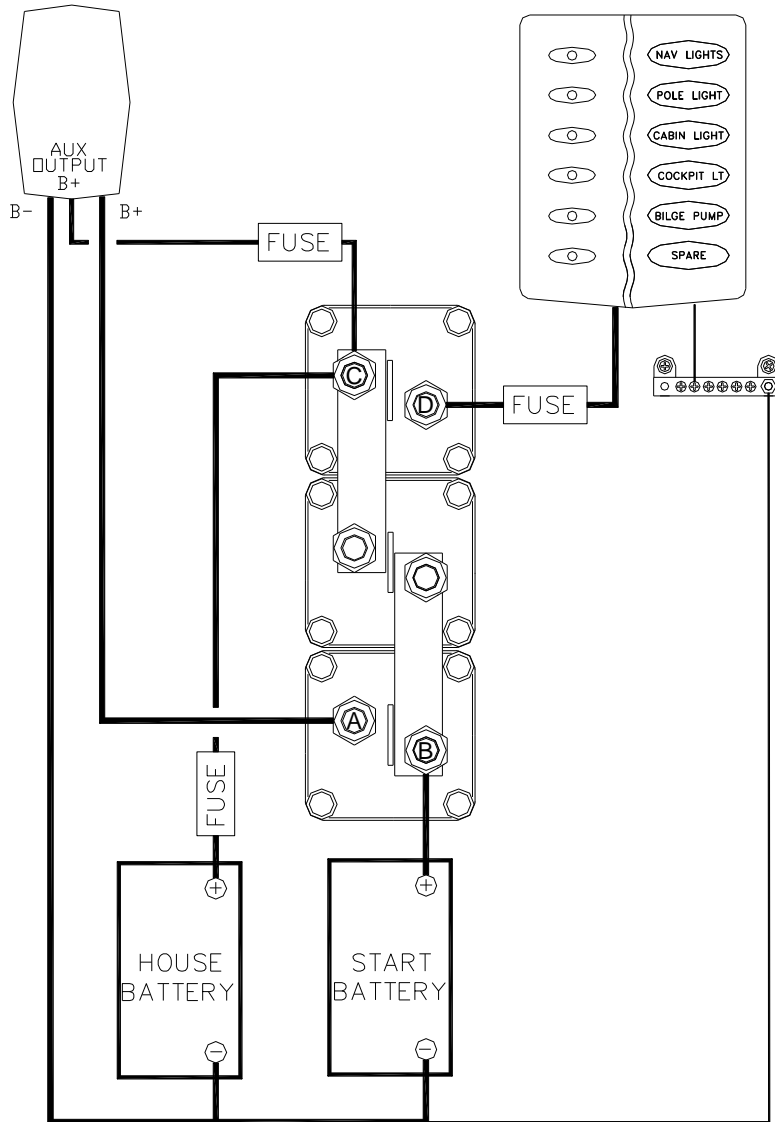

STUD A- CONNECT DIRECTLY TO THE POSITIVE OF THE OUTBOARD MAIN.

STUD B- CONNECT DIRECTLY TO THE POSITIVE TERMINAL OF THE START BATTERY.

STUD C- CONNECT TO THE POSITIVE TERMINAL OF THE HOUSE BATTERY VIA A FUSE. AND THE FUSED POSITIVE OF THE AUX. OUTPUT.

STUD D- CONNECT TO THE POSITIVE TERMINAL OF THE HOUSE LOAD THROUGH A FUSE.

NOTE: THIS DIAGRAM IS NOT INTENDED TO BE A FULL SYSTEMS WIRING DIAGRAM. IT'S SOLE PURPOSE IS TO SHOW 715V CONNECTIONS

| | | | | |
|-------|----------|-------------|--------------------|--------|
| DATE | 13/12/02 | DWG No. | INST-715V OVERVIEW | |
| DRAWN | S PLAYER | TITLE: | | |
| REV | DATE | DESCRIPTION | DRAWN | APPRVD |
| | | | | |
| | | | | |
| | | | | |

INSTALLATION DIAGRAM
FOR 715V

BEP MARINE LTD.

13 Tarndale Grove
Albany

Auckland 1310 N.Z.

PH 09 415 7261 FAX 09 415 9327

www.bepmarine.com

