

Installation Instructions

PT-0-3PSI-01, PT-0-5PSI-01, PT-0-10PSI-01, PT-0-50PSI-01, PT-0-100PSI-01, PT-0-300PSI-01, PT-0-500PSI-01, PT-0-1000PSI-01, PT-0-3000PSI-01, and PT-0-5000PSI-01 Pressure Transducers



WARNING – Maretron pressure transducers are **not** approved for use with gasoline. If you wish to use the FPM100 to monitor pressures or levels of gasoline, you must obtain a pressure transducer that is approved for use with gasoline.

Instructions

Please follow these instructions to connect any of the PT-0-3PSI-01, PT-0-5PSI-01, PT-0-10PSI-01, PT-0-50PSI-01, PT-0-100PSI-01, PT-0-300PSI-01, PT-0-500PSI-01, PT-0-1000PSI-01, PT-0-3000PSI-01, or PT-0-5000PSI-01 pressure transducers to the NMEA 2000® network via a Maretron FPM100 Fluid Pressure Module. The wiring diagram appears in Figure 1 below. The diagram shows a connection to channel #0, but connections to other channels are similar.

1. Please refer to the FPM100 User's Guide for detailed information on selecting a mounting location for the pressure transducer.
2. All Maretron pressure transducer assemblies are equipped with a 1/4" NPT male threaded fitting. Install the pressure transducer to a 1/4" NPT female fitting on the system or tank to be monitored with a maximum torque of 150 in-lbs (16.95 Nm). If you are monitoring a system where pressure spikes or transients will occur, or where the pressure will exceed the maximum pressure rating of the pressure transducer, install a Pressure Snubber (PT-SNUB-01) onto the system being monitored first, then install the pressure transducer to the female port on the pressure snubber.
3. Connect the two wires of the pressure transducer to a free pressure monitoring channel. Connect the red wire from the pressure transducer to the positive (+) terminal of the channel, and connect the white wire from the pressure transducer to the negative (-) terminal of the channel. The example in Figure 1 shows the pressure transducer connected to switch channel 0 with the red wire connected to "P0+", and the white wire connected to "P0-". Pressure transducers of "Gauge" type have a small plastic vent tube in the connecting cable. **Care must be taken not to kink or block this tube or allow it to be exposed to moisture, or pressure readings will be inaccurate.**
4. Use a Maretron DSM250 display (firmware 1.4.7 or higher), the DSM250 viewing function of the Maretron N2KAnalyzer software, or other Maretron display product capable of configuring the FPM100 to configure the connected channel. Please refer to the FPM100 User's Manual for configuration details.
5. Supply Power to the NMEA 2000 network and verify that the pressure channel indicates a valid pressure reading.

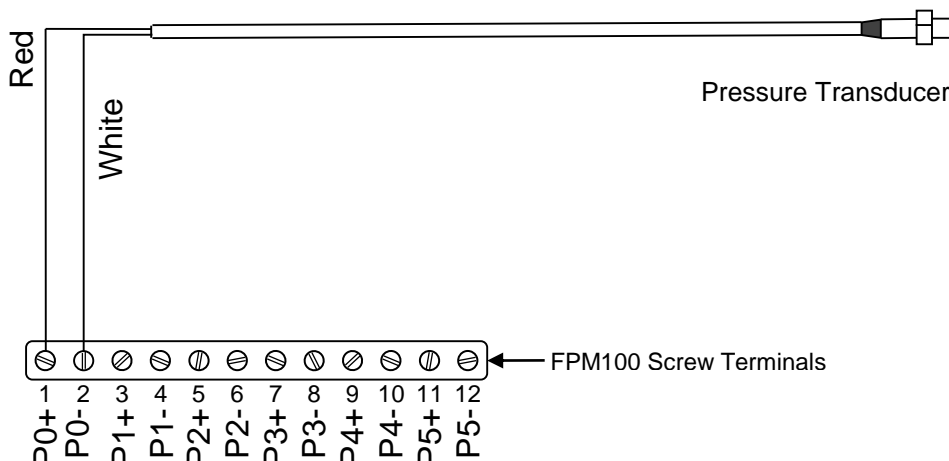
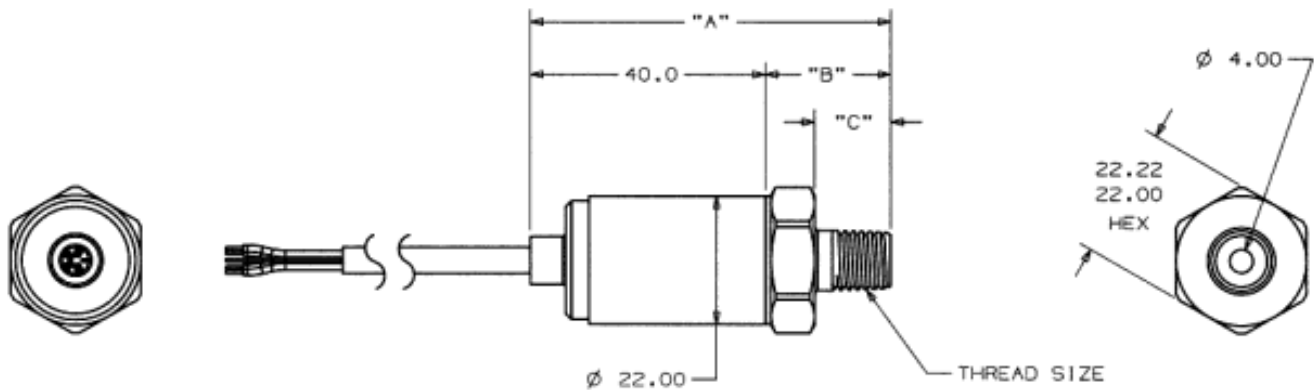

Figure 1 – Pressure Transducer Connection Diagram

Pressure Transducer Mechanical Drawing



THREAD SIZE	LENGTH "A"	LENGTH "B"	LENGTH "C"
1/4-18 NPT	66.6	26.0	18.0

Pressure Transducer Specifications

Part Number	Range	Accuracy	Type
PT-0-3PSI-01	0 to 3 PSI (0.21 bar)	±2% Full Scale	Gauge (Vent Tube)
PT-0-5PSI-01	0 to 5 PSI (0.34 bar)	±2% Full Scale	Gauge (Vent Tube)
PT-0-10PSI-01	0 to 10 PSI (0.69 bar)	±2% Full Scale	Gauge (Vent Tube)
PT-0-50PSI-01	0 to 50 PSI (3.45 bar)	±1% Full Scale	Gauge (Vent Tube)
PT-0-100PSI-01	0 to 100 PSI (6.89 bar)	±0.5% Full Scale	Gauge (Vent Tube)
PT-0-300PSI-01	0 to 300 PSI (20.68 bar)	±0.5% Full Scale	Gauge (Vent Tube)
PT-0-500PSI-01	0 to 500 PSI (34.47 bar)	±0.5% Full Scale	Absolute (No Vent Tube)
PT-0-1000PSI-01	0 to 1000 PSI (68.95 bar)	±0.5% Full Scale	Absolute (No Vent Tube)
PT-0-3000PSI-01	0 to 3000 PSI (206.84 bar)	±0.5% Full Scale	Absolute (No Vent Tube)
PT-0-5000PSI-01	0 to 5000 PSI (344.74 bar)	±0.5% Full Scale	Absolute (No Vent Tube)

Specification	Value
Compatible Fluids / Gases	Refrigerant, Motor Oil, Diesel, Hydraulic Fluid, Brake Fluid, Water, Waste Water, Hydrogen, Nitrogen, Air
Operating Temperature	-40°C to 105°C
Storage Temperature	-40°C to 105°C
Proof Pressure	2.4 x Full Scale
Burst Pressure	2.4 x Full Scale
Reverse Voltage Protection	± 16V over 5 Minutes
Construction	304L stainless steel
Cable Length	3 feet (0.91m)
Pressure/Temperature Cycles	0 to FS @ 8Hz; and -40°C to 105°C for > 1.8x10 ⁶ cycles
Thermal Shock	105°C to -40°C, 0.5 hr soaks at Temp. (2s Transfer) for 300 cycles
Vibration	100 to 2000 Hz, 20g Sinusoidal, 3 Axes for 144 hours
EMC Compatibility	10 Volts/meter per EN 61000-4-3
Humidity	85°C and 90% to 95% R. H. for 250 hours
Weight	85g

For installation support, please contact:

Maretron, LLP
9014 N. 23rd Ave #10
Phoenix, AZ 85021-7850
Telephone: (+1) 866-550-9100
E-mail: support@maretron.com
Web: <http://www.maretron.com>