

CA-Stream printed manual 2017-05-21

Shakespeare® STREAM™

WIRELESS BOOSTER

User and Installation Guide

Shakespeare
CA-Stream
User Guide



05.21.2019

Activate your three-year manufacturer's warranty at www.surecall.com/activate

Powered by
SureCall®

Introduction

Congratulations on purchasing the Shakespeare Stream, the finest internet available!

Designed for boats of all sizes, the Stream uses Shakespeare’s state-of-the-art cellular phone booster technology to amplify weak cell signals along popular inshore and coastal cruising routes, enabling boaters to use their existing data plans* to host a reliable wireless hotspot on their phone or cellular-enabled tablets.

*Data plans vary by cellular provider. Check with your carrier for plan specifics.

TABLE OF CONTENTS

Operation.....	2
Package Contents	3
Installation Overview	4
Before Installation	5
Step 1. Install the Helm Antenna.....	5
Step 2. Mount Outside Antenna	6
Step 3. Mount Booster	7
Step 4. Connect Cables.....	8
Step 5. Connect Power.....	8
LED Indicators	9
Troubleshooting.....	9
Antenna Kitting Information.....	10
Consumer Guidelines	11
Three-Year Product Warranty	12
Specifications CA-Stream	13

OPERATION

The Shakespeare Stream works with two antennas.

1. Outside Antenna. Communicates with the cell towers on land.
2. Internal Antenna. Black patch antenna. Delivers cellular signal to and from your cellular device (phone, tablet, or mobile hotspot).

Signals sent from a cell tower are received by the outside antenna, processed and amplified by the wireless booster and sent to your cellular device via the internal helm antenna.

When your cellular device transmits, the signal is sent to the internal helm antenna and then to the cell tower via the outside antenna.

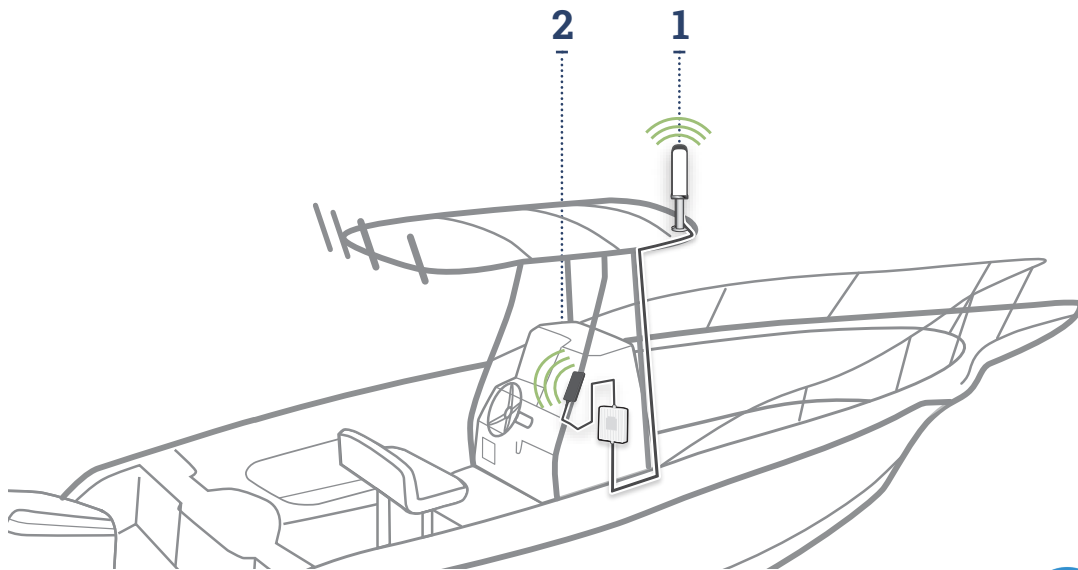

Some cell signal is required for the Stream to enhance cellular signal coverage. Download the “OpenSignal” app on a mobile phone to understand coverage in the areas where you boat.

Simply search for “Open signal” in the app store and look for their logo.



Introduction

PACKAGE CONTENTS

1. Unpack all package contents. For missing or damaged items, contact your reseller.
2. Turn over the signal booster and record the model and serial number for reference:

Serial #: _____

Purchase Date: _____

3. Keep the carton and packing material to store the product in case you need to return it.

Your Stream signal booster package includes the following items:

- Stream Marine Wireless Booster
- 12V DC power cable, 18 ft.
- Helm antenna with 10 ft. cable
- Outside marine antenna with mount
- Low loss coax cable, 20 ft.



Stream Wireless
Booster



12v DC Power
Cable
18 ft.



Helm
Antenna
10 ft.



Outside Marine
Antenna



Low-loss Cable
20 ft.

INSTALLATION OVERVIEW

**Quick
Overview**

1. Place helm antenna within 1-2 inches of typical cellular device location
2. Mount outside antenna in an elevated position
3. Mount booster within console panel
4. Connect cables to booster
5. Connect booster to power source

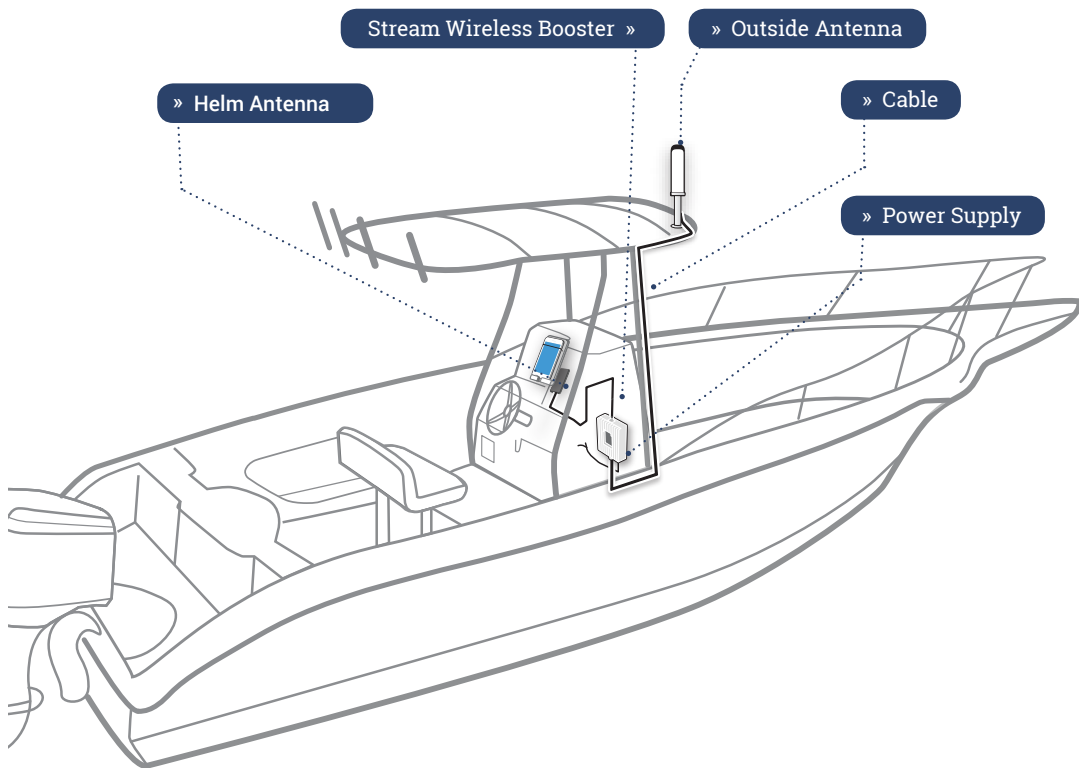

Installation

BEFORE INSTALLATION

Please read through instructions in their entirety before proceeding. A “soft installation” is strongly recommended prior to securing any cable or permanently fixing any parts, as adjustments may be needed.

Also, please note the following key factors to optimizing performance:

1. Antenna separation: Ensure a minimum of 3 feet in separation between outside antennas and the helm antenna
2. Helm antenna placement: Location of the helm antenna should be within 2 inches of your cellular device. Ideal mounting locations include beneath a phone mount or just below your console panel where a cellular device can be placed.

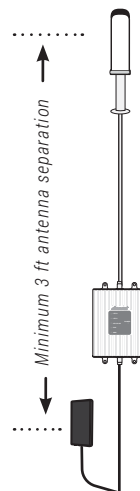

STEP 1. INSTALL THE HELM ANTENNA

Choose a location for the inside antenna where increased signal is needed. Identify a location that is

1. Within 2 inches of typical cell phone location
2. At least 8 inches (20cm) from any person
3. At least 4 inches (10cm) from metal

Consider using a dash mount phone holder like the ones shown below. Newer boats may come with similar holders pre-fabricated into the dash.

Within 1 & 2 inches

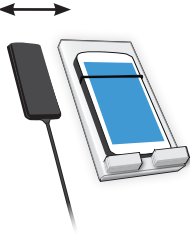

Antenna mounted beside holder

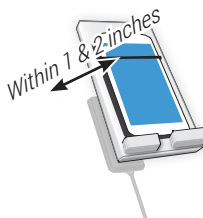

Antenna mounted behind holder

* Note: The FCC prohibits physical contact between the inside antenna and a cellular device in higher power units like the Stream. Maintain a clear gap between the cellular device and inside antenna.

* Note: Do not mount the inside antenna on or near metal surface or objects. Do not choose a metallic phone holder as it may affect the performance of the Stream.

STEP 2. MOUNT OUTSIDE ANTENNA

Choose a location for the outside antenna. The location should be:

- At least a 12-inches from obstructions and other radiating elements, such as a radio antenna.
- As high as possible and oriented vertically
- At minimum, 3 ft. away from the location of the helm antenna.



PLEASE REFRAIN FROM MAKING ANY PERMANENT STRUCTURE CHANGES (SUCH AS DRILLING ANY HOLES) OR PERMANENTLY SECURING BOOSTER COMPONENTS UNTIL INSTALLATION IS COMPLETE AND THE SYSTEM HAS BEEN TESTED.

Once you have identified optimal mounting location that meet the requirements listed above, determine the necessary route that cable will take from the from within your center console to outside antenna, considering any necessary accommodations before proceeding.

We recommend mounting the antenna to an appropriate surface through which a hole may be drilled and the cable may pass. However, if this is not possible, an alternative mounting solution is available that allows cable to exit through the ferrule. See below diagram for assembly and installation.

» 3 Ferrule connects to base mount

» 2 Base Mount (screws not provided) mounts directly to mounting surface

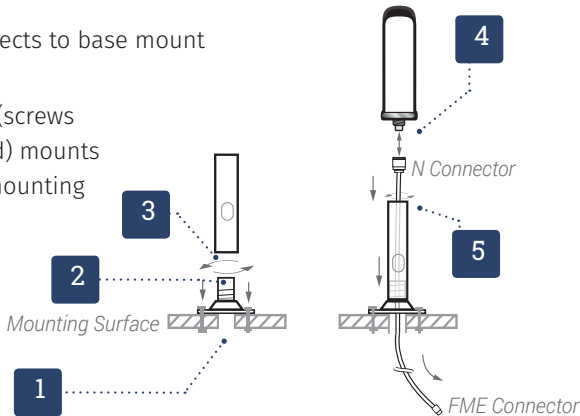

» 4 Cable passes through ferrule, connecting top end N-connector to the antenna and sending the open FME connector down through mounting surface

» 1 Mounting surface with drilled hole, wide enough in diameter to allow both cable and connector to pass through

» 5 Antenna secures in place onto ferrule

* Note: The outside antenna must not be collocated or operating with any other antenna or booster.

Installation

If you are not able to run cable through a drilled hole in your mounting surface, see alternative mounting solution below:

- » 1 Alternatively, a removable cap on the ferrule allows cable to be passed through the ferrule rather than directly through the mounting surface as shown in the illustration.

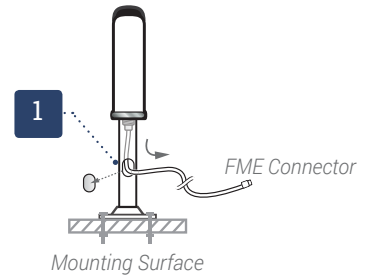

ALTERNATIVE MOUNTING OPTION

STEP 3. MOUNT BOOSTER

Select a well-ventilated location for the booster that is away from excessive heat, direct sunlight, and moisture. The booster should be mounted vertically using booster screw fittings.

Place booster unit temporarily in your chosen location until cables are in place. Plan how cables will be routed to the booster.

If the cables are not long enough, consider relocating the booster unit and/ or antennas while keeping in mind the constraints of step 1 & 2.

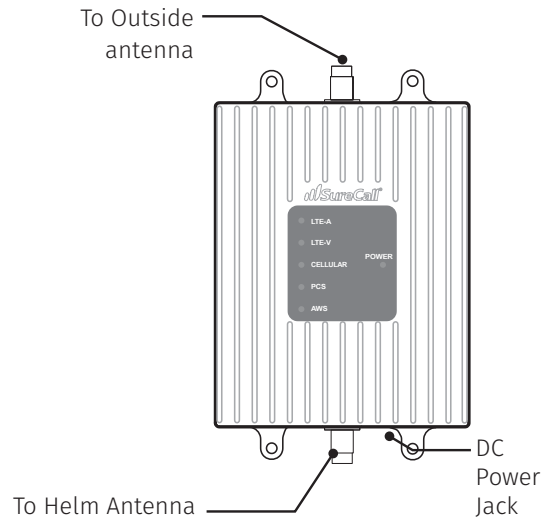

STEP 4. CONNECT CABLES

Use the 20 ft. of cable and route from outside antenna to the booster. Connect the cable from the outside antenna to the connection marked OUTSIDE. Route the cable immediately down and away from the outside antenna, not wrapped or draped near it. When securing the cable, be sure to remove any kinks or loops.

Next, route the cable from helm antenna to the connection marked INSIDE. Tighten the connections and secure any loose cable.

STEP 5. CONNECT POWER

It is highly recommended to run the power line through a rocker switch or circuit breaker to ensure power is not drawn when not in use.

The positive red and negative black wired end will connect to watercraft's power supply - either battery, ignition or fusebox - whichever is located most conveniently.

Connect the DC power cord to the booster.

- When the power LED turns ON, the booster is ready for use.
- The Alert LEDs flash up to 15 seconds to show the frequency band is operational.

Note: While the watercraft is in port, the alert light may flash green slowly. This means that the booster is self-adjusting due to over-signal. The Shakespeare Stream auto adjusts the gain if there is a strong signal like at the dock. Thus, the lights may flash green in such situations.

Flashing will resolve, returning to full power once you leave the dock.

If red alert LEDs appear, increased antenna separation is likely needed. For more information, see "LED Indicators" on page 9.

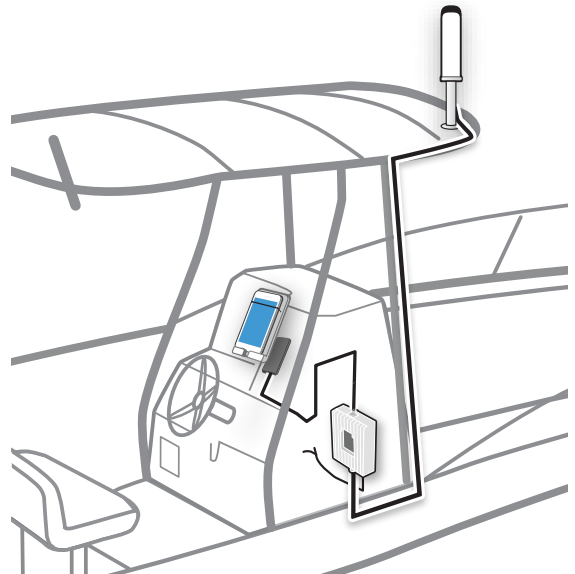

* **WARNING.** This booster is rated for 5-15V input voltage. DO NOT use the booster with a higher voltage power supply. This can damage the booster and/or cause personal injury.

Troubleshooting

Avoiding Interference

If the booster interferes with your radio or other electronic receivers, move the booster further away from those devices.

Frequently Asked Questions

For a list of Frequently Asked Questions and a comprehensive, up-to-date Troubleshooting Guide, please visit www.surecall.com.

Obtaining Technical Support

You can also consult a SureCall technical specialist directly by emailing support@surecall.com, or call 1-888-365-6283 and ask for tech support.

LED INDICATORS

Place a call in a location you have previously experienced poor signal and confirm that your phone is receiving a boosted signal. Normal operation is indicated by Green LEDs (both flashing and solid). In the event Red LEDs appear, antenna adjustments may be needed.

Color	Condition	Indication
Green	Solid	Indicates normal operation.
Green	Flashing	Normal operation. Indicates that Automatic Gain Control (AGC) is self-adjusting due to over-signal or antenna proximity.
Red	Flashing	Indicates issues caused by oscillation. Adjustment of your outside antenna placement is likely needed. Verify that it has sufficient separation from the inside antenna, as well as, any potentially interfering objects or antennas

Note that the booster case may become warm during operation. This is normal.

TROUBLESHOOTING

Problem	Resolution
Signal booster has no power	Verify that the Power LED is ON. Connect the power supply to an alternate power source. Verify that the power source is operational and the fuse is intact. If it remains OFF, contact tech support at: 1-888-365-6283 or support@surecall.com
After completing installation, signal has not improved	Ensure that you are testing the booster in an area with weak signal strength. Verify that cable connections are tightly fitted to the booster. Try further separating the antennas. Note: Bars are not always a reliable measure of signal. The best way to confirm signal coverage is the ability to place and hold a call.

ANTENNA KITTING INFORMATION

Component	Prod No. Description	Gain				
		LTE-A	LTE-V	800 MHz	1900 MHz	1700 MHz / 2100 MHz
Shakespeare Stream Marine Booster						
Outdoor Antenna and Cable	SC288W / Galaxy 5412-P and SC240-20FN (20 ft)	0.94 dB	0.94 dB	0.71 dB	0.44 dB	0.64 dB / 0.24 dB
Indoor Antenna and Cable	SC110W and SC174-10 ft (10 ft)	-2.7 dB	-2.7 dB	-3.2 dB	-5.8 dB	-3.98 / -5.96 dB

*All equivalent antennas and cables are suitable for use with the Stream [Fusion2Go 3.0]

Warning: Unauthorized antennas, cables, and/or coupling devices are prohibited by FCC new rules. Changes or modifications not expressly approved by SureCall could void the user’s authority to operate the equipment.

FCC 27.50(d)(4) Statement: Fixed, mobile and portable (hand-held) stations operating in the 1720-1755 MHz band are limited 1 Watt EIRP. Fixed stations operating in this band are limited to a maximum antenna height of 10 meters above ground. Mobile and portable stations operating in this band must employ a means for limiting power to the minimum necessary for successful communications.

FCC 15.105 Statement This equipment has been tested and found to comply with the limits for a Class B digital device, pursuant to part 15 of the FCC Rules. These limits are designed to provide reasonable protection against harmful interference in a residential installation. This equipment generates, uses and can radiate radio frequency energy and, if not installed and used in accordance with the instructions, may cause harmful interference to radio communications. However, there is no guarantee that interference will not occur in a particular installation. If this equipment does cause harmful interference to radio or television reception, which can be determined by turning the equipment off and on, the user is encouraged to try to correct the interference by one or more of the following measures:

- Reorient or relocate the receiving antenna
- Increase the separation between the equipment and receiver.
- Connect the equipment into an outlet on a circuit different from that to which the receiver is connected
- Consult the dealer or an experienced radio/TV technician for help.

15.19 This device complies with Part 15 of the FCC Rules. Operation is subject to the following two conditions: (1) this device may not cause harmful interference, and (2) this device must accept any interference received, including interference that may cause undesired operation.

Safety Information

CONSUMER GUIDELINES

This is a CONSUMER device

BEFORE USE, you **MUST REGISTER THIS DEVICE** with your wireless provider and have your provider's consent. Most wireless providers consent to the use of signal boosters. Some providers may not consent to the use of this device on their network. If you are unsure, contact your provider.

You **MUST** operate this device with approved antennas and cables as specified by the manufacturer. Antennas **MUST** be installed at least 20 cm (8 inches) from (i.e. MUST NOT be installed within 20 cm of) any person.

You **MUST** cease operation of this device immediately if requested by the FCC or a licensed wireless service provider.

WARNING: E911 location information may not be provided or may be inaccurate for calls served by using this device.

Register your cellular booster with your wireless carrier at the following urls:

Verizon: <http://www.verizonwireless.com/wcms/consumer/register-signal-booster.html>

AT&T: <https://securec45.securewebsession.com/attsignalbooster.com/>

T-Mobile: <https://support.t-mobile.com/docs/DOC-9827>

Sprint: https://www.sprint.com/legal/fcc_boosters.html

U.S. Cellular: <http://www.uscellular.com/uscellular/support/fcc-booster-registration.jsp>



WARNING

This product can expose you to chemicals, including Nickel, which are known to the state of California to cause cancer and reproductive harm.

For more information go to www.P65Warnings.ca.gov



This is a CONSUMER device

BEFORE USE, you **MUST REGISTER THIS DEVICE** with your wireless provider and have your provider's consent. Most wireless providers consent to the use of signal boosters. Some providers may not consent to the use of this device on their network. If you are unsure, contact your provider.

You **MUST** operate this device with approved antennas and cables as specified by the manufacturer. Antennas **MUST** be installed at least 20 cm (8 inches) from (i.e. MUST NOT be installed within 20 cm of) any person.

You **MUST** cease operation of this device immediately if requested by the FCC or a licensed wireless service provider.

WARNING: E911 location information may not be provided or may be inaccurate for calls served by using this device.

THREE-YEAR PRODUCT WARRANTY

Register at www.SureCall.com/activate

SureCall warrants its products for three years from the date of purchase against defects in workmanship and/or materials. Specifications are subject to change. The three-year warranty only applies to products meeting the latest FCC Certification Guidelines stated on 2/20/2013 and going into effect April 30, 2014. A two-year warranty applies to any products manufactured before May 1, 2014.

Products returned by customers must be in their original, un-modified condition, shipped in the original or protective packaging with proof-of-purchase documentation enclosed, and a Return Merchandise Authorization (RMA) number printed clearly on the outside of the shipping container.

Buyers may obtain an RMA number for warranty returns by calling the SureCall Return Department toll-free at 1-888-365-6283. Any returns received by SureCall without an RMA number clearly printed on the outside of the shipping container will be returned to sender. In order to receive full credit for signal boosters, all accessories originally included in the signal booster box must be returned with the signal booster. (The Buyer does not need to include accessories sold in addition to the signal booster, such as antennas or cables.)

This warranty does not apply to any product determined by SureCall to have been subjected to misuse, abuse, neglect, or mishandling that alters or damages the product's physical or electronic properties.

SureCall warrants to the Buyer that each of its products, when shipped, will be free from defects in material and workmanship, and will perform in full accordance with applicable specifications. The limit of liability under this warranty is, at SureCall's option, to repair or replace any product or part thereof which was purchased up to THREE YEARS after May 1, 2014 or TWO YEARS for products purchased before May 1, 2014, as determined by examination by SureCall, prove defective in material and/or workmanship. Warranty returns must first be authorized in writing by SureCall. Disassembly of any SureCall product by anyone other than an authorized representative of SureCall voids this warranty in its entirety. SureCall reserves the right to make changes in any of its products without incurring any obligation to make the same changes on previously delivered products.

As a condition to the warranties provided for herein, the Buyer will prepay the shipping charges for all products returned to SureCall for repair, and SureCall will pay the return shipping with the exception of products returned from outside the United States, in which case the Buyer will pay the shipping charges. The Buyer will pay the cost of inspecting and testing any goods returned under the warranty or otherwise, which are found to meet the applicable specifications or which are not defective or not covered by this warranty.

Products sold by SureCall shall not be considered defective or non-conforming to the Buyer's order if they satisfactorily fulfill the performance requirements that were published in the product specification literature, or in accordance with samples provided by SureCall. This warranty shall not apply to any products or parts thereof which have been subject to accident, negligence, alteration, abuse, or misuse. SureCall makes no warranty whatsoever in respect to accessories or parts not supplied by it.

Limitations of Warranty, Damages and Liability:

EXCEPT AS EXPRESSLY SET FORTH HEREIN, THERE ARE NO WARRANTIES, CONDITIONS, GUARANTEES, OR REPRESENTATIONS AS TO MERCHANTABILITY, FITNESS FOR A PARTICULAR PURPOSE, OR OTHER WARRANTIES, CONDITIONS, GUARANTEES, OR REPRESENTATIONS, WHETHER EXPRESSED OR IMPLIED, IN LAW OR IN FACT, ORAL OR IN WRITING.

SURECALL AGGREGATE LIABILITY IN DAMAGES OR OTHERWISE SHALL NOT EXCEED THE PAYMENT, IF ANY, RECEIVED BY CELLPHONE-MATE, INC. FOR THE UNIT OF PRODUCT OR SERVICE FURNISHED OR TO BE FURNISHED, AS THE CASE MAY BE, WHICH IS THE SUBJECT OF CLAIM OR DISPUTE. IN NO EVENT SHALL SURECALL BE LIABLE FOR INCIDENTAL, CONSEQUENTIAL, OR SPECIAL DAMAGES, HOWSOEVER CAUSED.

All matters regarding this warranty shall be interpreted in accordance with the laws of the State of California, and any controversy that cannot be settled directly shall be settled by arbitration in California in accordance with the rules then prevailing of the American Arbitration Association, and judgment upon the award rendered may be entered in any court having jurisdiction thereof. If one or more provisions provided herein are held to be invalid or unenforceable under applicable law, then such provision shall be ineffective and excluded to the extent of such invalidity or unenforceability without affecting in any way the remaining provisions hereof.

SureCall has made a good faith effort to ensure the accuracy of the information in this document and disclaims the implied warranties of merchantability and fitness for a particular purpose and makes no express warranties, except as may be stated in its written agreement with and for its customers. SureCall shall not be held liable to anyone for any indirect, special or consequential damages due to omissions or errors. The information and specifications in this document are subject to change without notice.

© 2019. All Rights Reserved. All trademarks and registered trademarks are the property of their respective owners.



6111 Shakespeare Road
Columbia, SC 29223
www.shakespeare-marine.com

SPECIFICATIONS CA-STREAM

Uplink Frequency Range (MHz):	698-716 / 776-787 / 824-849 / 1850-1915 / 1710-1755
Downlink Frequency Range (MHz):	728-746 / 746-757 / 869-894 / 1930-1995 / 2110-2155
Input / Output Impedance:	50 Ω
Maximum Gain:	50 dB
Maximum Uplink Power:	29.0 dBm
Noise Figure:	≤ 5 dB
VWSR:	≤ 2.0
Supported Standards:	CDMA, WCDMA, GSM, EDGE, HSPA+, EVDO, LTE and all cellular standards
Maximum Output Power:	1 Watt EIRP
Cable:	SC-174 / SC-240
RF Connectors:	FME Male (both ends)
Power Supply / Consumption:	6-15V DC, 2.1A Max. @ 12 V DC
Dimensions:	5.625 x 4 x 1.125 inches
Weight:	1.43 lbs
RoHS Compliant:	Yes
Certification:	FCC ID: RSNF2G03 (fusion2go 3.0 [Shakespeare Stream])

SHAKESPEARE ELECTRONIC PRODUCTS GROUP

© 2019 Shakespeare Company, LLC. All rights reserved.