

TACO Marine® Pro Series Grand Slam Outrigger Mounts

GS-500/GS-500XL

INSTALLATION INSTRUCTION GUIDE

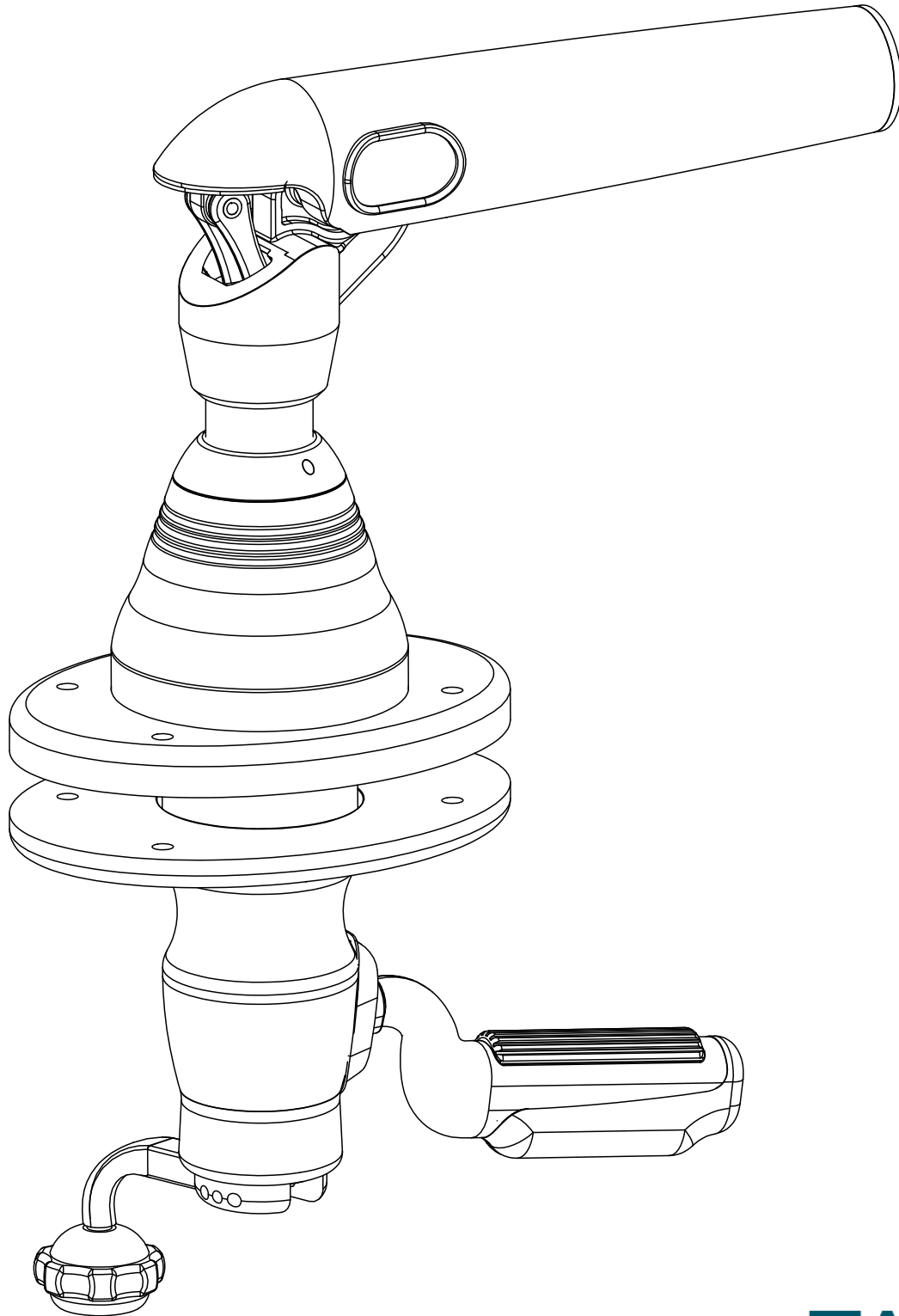

Kit Contents

GS-500

2

Grand Slam 500 mounts

500 or 500XL

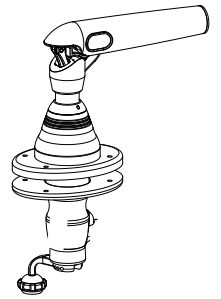

2

Aluminum backing plate

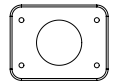

Included for extra strength and recommended when mounting on a hardtop

8

Stainless-steel button head cap bolts



GS-500: 5/16" - 18 TPI x 3-1/2"
GS-500XL: 5/16" - 18 TPI x 5-1/2"

8

5/16" hex nuts

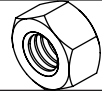

8

5/16" stainless-steel washers



TACO[®]

Handy Tips

- Ensure your Canvas T-Top or Hardtop is suitably constructed to provide a strong mounting surface area for your outrigger base. The GS-500/500XL was designed for high-performance sport fishing center consoles with three or more engines.
- If the top is arched, wedge plates can be used to maintain proper alignment.
- The Grand Slam outrigger bases in your kit are a pair of Port and Starboard units. These are labeled "P" for port side and "S" for starboard.

00/500XL

Required*

*not included

- 3-1/8-" HOLE SAW
- DRILL
- MASKING TAPE
- WRENCH
- 4MM ALLEN WRENCH

8

Vinyl tubing spacer



8

Nylon fiber flat washers



2

Installation drill templates

2

Rotator handles

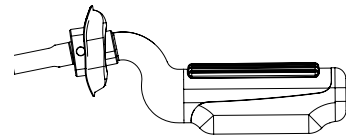

4

Hex Bolts 4mm for Rotator Handles



- The supplied template is only a guide to help align base for hole positioning. There should be no contact between the mount and 3-1/8" hole.
- Always place a nylon 5/16" washer underneath any stainless-steel washer to prevent corrosion of the Grand Slam's base. Place bead of marine-grade silicone sealant around hole in mounting plate.

NOTE: Bolts, washers and nuts are provided. However, if you purchase your own, always use good quality Type-304 or 18-8 stainless-steel hardware when mounting the base.

NOTE: The maximum hardtop thickness allowable for GS-500 is 2" and for the GS-500XL is 4".

Do not attempt to weld the base to anything.

Installation

2

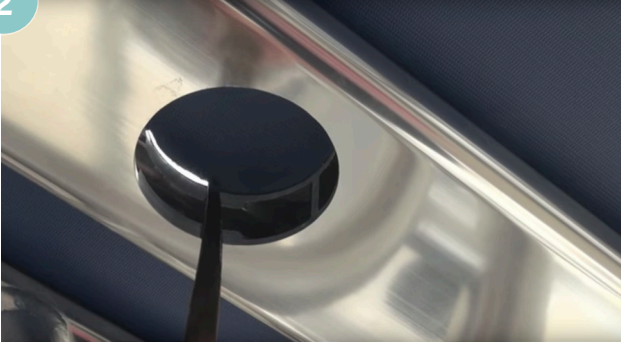

CANVAS TOP

IMPORTANT: To mount the Pro Series GS-500 Outrigger Mounts to a canvas top frame, TACO recommends ensuring the necessary extrusion plates are of high-quality materials and installed by a reputable welder who can verify the top size and structure can support the mounts. If the canvas top has pre-drilled holes for heavy-duty outriggers, the included backing plates, spacers, bottom washers and hex nuts may not be needed. Please consult a reputable installer for verification.

6



1. Prepare the canvas for installation by cleaning it.
2. Use an old fillet knife and heat it up with a torch to where it's almost red-hot. Use the hot fillet knife to cut and seal the canvas in order to keep it from unraveling.
3. Find each pre-drilled hole and mark it with a magic marker to make it easy to find.
4. Use an old screw driver and heat it up with a torch as done previously with the screwdriver.
5. Use the hot screwdriver to poke a hole through the canvas for the bolts.
6. Go around the main opening and each pre-drilled hole and apply some clear marine-grade silicone before you set the base.
7. Set the base through the 3-1/8" hole and align the bolt holes.
8. Using the Head Cap Bolt, place the stainless-steel washer first, and then follow it with the nylon washer.
9. Use the Allen Wrench to screw the hardware into the base.
10. Wipe the extra marine-grade silicone off the canvas.
11. Place the handle into the base with the finger grips up and verify that the elongated notch in the tube faces out. Put the 4mm hex bolt in place and then tighten it slightly with a 4mm allen wrench Then do the same thing with the top bolts.
12. Once both bolts are in place, torque them evenly before testing the Mount.
13. Check the different angle position settings by pulling down on the handle and rotating the base back and forth.

8



11



Images are examples only and not reflective of the GS-500 appearance.



KEY

- A GRAND SLAM MOUNT
- B ALUMINUM BACKING PLATE
- C STAINLESS-STEEL BUTTON HEAD CAP BOLT
- D NYLON WASHER
- E STAINLESS-STEEL WASHER
- F VINYL TUBING SPACER*
- G HEX NUT
- H ROTATOR HANDLE
- I 4MM HEX BOLT
- J PRE-ASSEMBLED CRANK HANDLE

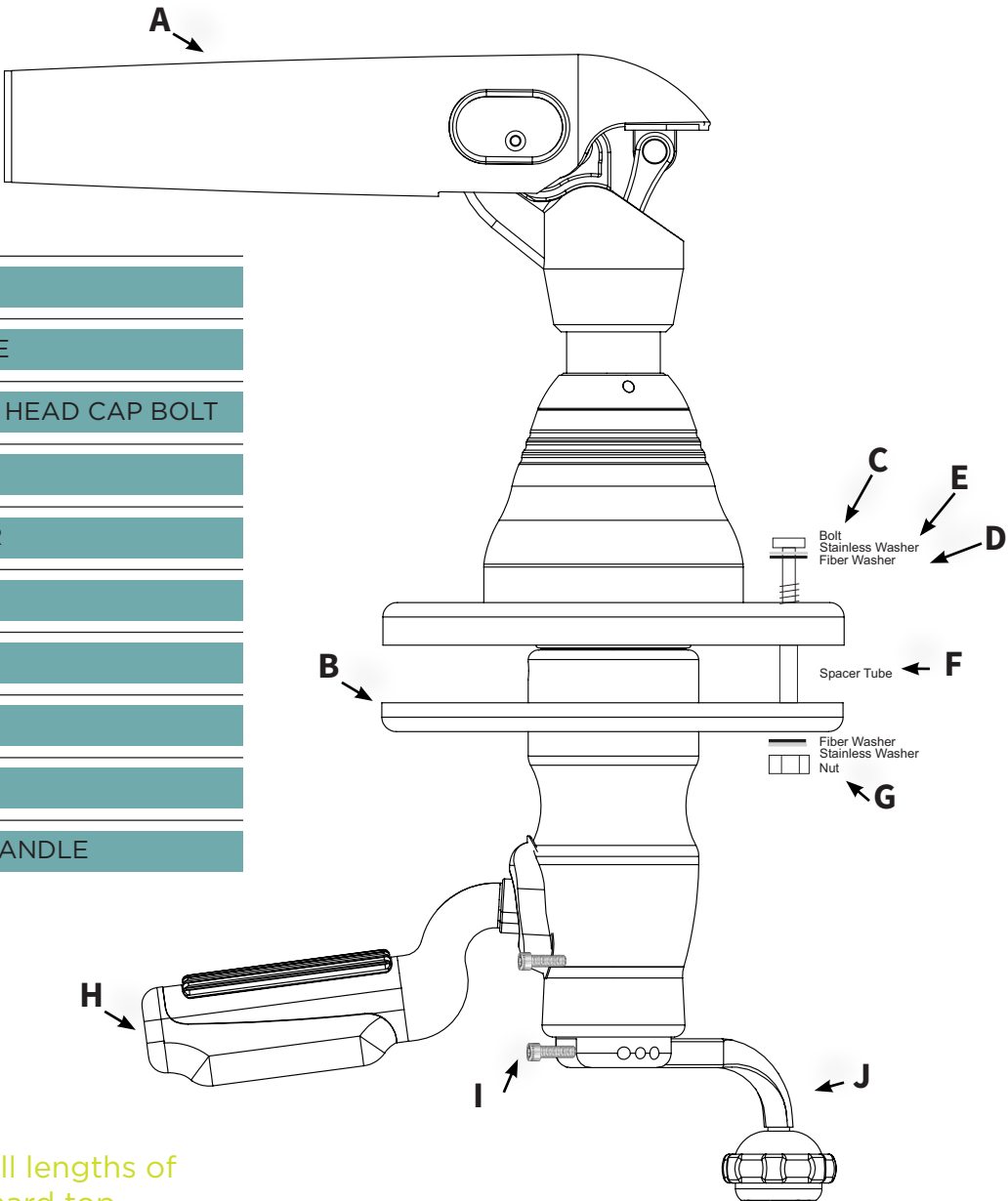

NOTE*

Vinyl tubing spacers are small lengths of tubing cut to size based on hard top thickness. The tubing spacers add additional support to ensure that when the bolts are tightened the top is not compressed.

Figure 5: Technical drawing with hardware for GS-500/500XL

HARDTOP INSTALL

When installing through a hardtop, make sure the top is foam or core filled. It is recommended to use included spacers provided (small lengths of tubing cut to size based on hardtop thickness). The tubing spacers add additional support to fit inside the hardtop where the mounting bolts pass through to ensure that when the bolts are tightened the top is not compressed.

1. Prepare for installation by cleaning the hardtop.
2. Find the desired location to cut out a 3-1/8" diameter hole where the outrigger base will drop through the hardtop.
3. Once the location of the holes are identified, tape the entire section where the bolts will be drilled, both on the top and bottom of the hardtop.
NOTE: Masking tape reduces the chances of the drill bit or hole saw chipping the fiberglass.
4. Using the supplied Drill Template as a guide, tape it to the top side of the fiberglass hardtop to begin drilling the 3-1/8" hole. Pilot drill through the hardtop. Afterward, drill the 3-1/8" hole halfway through the top and bottom.
NOTE: Drilling from both sides of the hardtop reduces the chances of chipping the fiberglass.
5. Next, open the bottom crank handle on the outrigger base and slide it through the hole - being careful not to scratch the anodized finish of the lower components. Before drilling the four hardware mounting holes on each outrigger base, install the outrigger poles on to the bases to achieve best position for alignment.
6. The supplied template is only a guide to help align bases for true hole positioning. Make sure nothing is rubbing in the 3-1/8" hole. There should be a small gap all the way around.
7. When the Grand Slam bases are aligned, mark and drill out the four hardware mounting holes on each mount.
8. Add a ring of marine-grade silicone around the 3-1/8" hole to prevent any water from leaking through the hole.
9. If using a backing plate, put a bead of marine-grade sealant on the underside of the backing plate. This prevents water drips.



How to clean

Always use a mild, non-abrasive soap and lots of fresh water. Thoroughly wash the aluminum with a soft towel or sponge - utilizing lots of soap and water to remove all dried salt crystals and other contaminants. Rinse completely with direct water pressure. It is recommended to use a small amount of marine grade lubricant where the outrigger arm comes out of the base. This will keep the seals lubricated.

Safe Cleaners

Mild dish washing liquid, specialty marine cleaners:

Sea Safe Boat Wash, Boat Wash Concentrate and Super Suds.

Safe marine lubricants:

CRC Corrosion Inhibitor, Corrosion Block and Get Some Extreme.

Harmful Cleaners

Bleach (Clorox, etc.) and mild abrasive cleaners:

Ajax, Comet, Soft Scrub, Rubbing Compounds, etc.

Strong cleaners:

409, Engine Degreasers, etc.

Acids of any type:

Such as, Muriatic, naval jelly or aluminum acid.

NOTE:

Mounting hardware is provided with all outrigger mounts. The length of the bolts required for proper installation will vary by the size of the hard top.

Need Support?

Contact Us



1.800.653.8568



support@tacomarine.com



tacomarine.com



50 NE 179th ST
Miami, FL. 33162



@tacomarine



@taco_marine

TACO Marine®

GS 500/ 500XL Drill Template

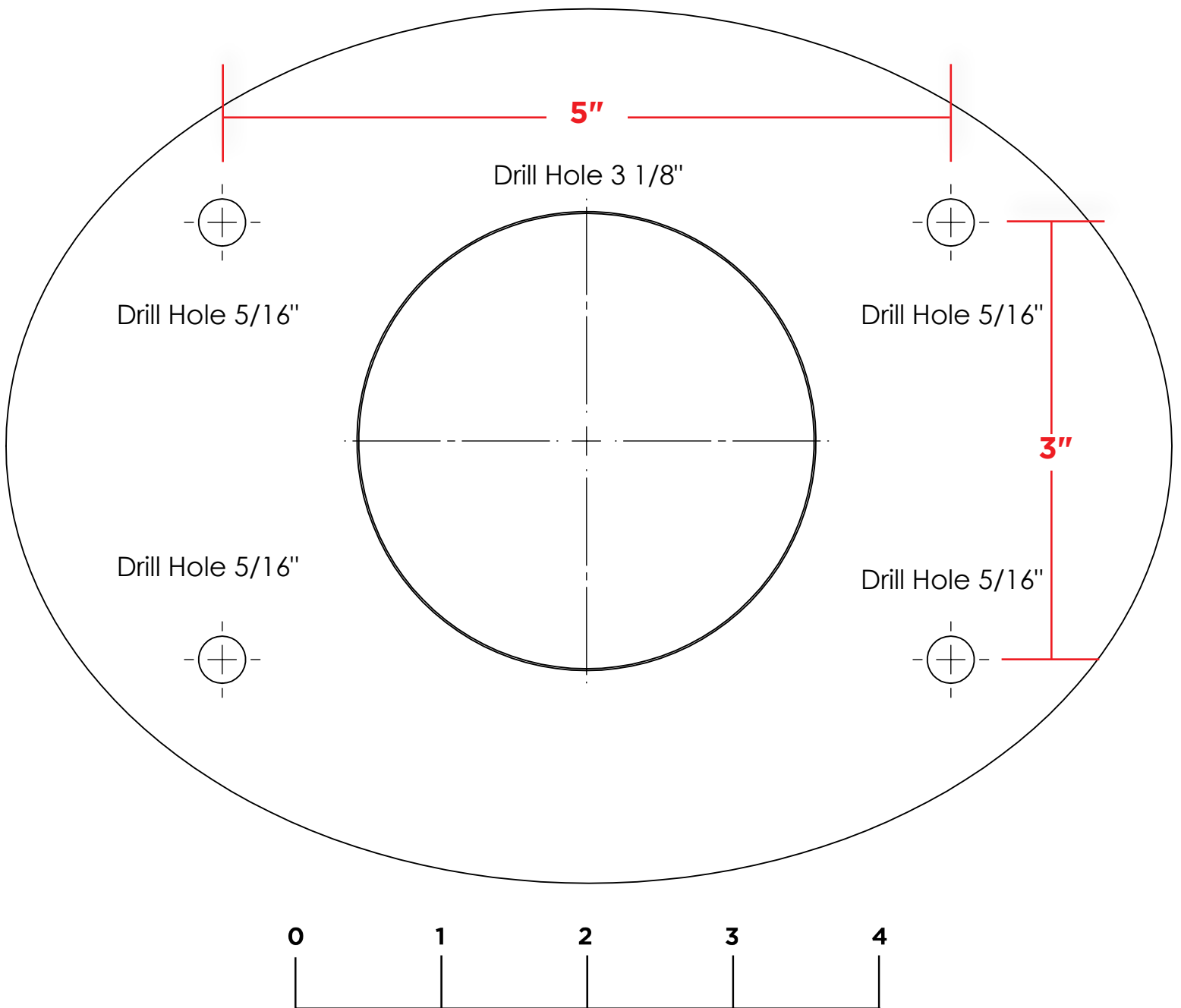

Please print at 100 percent for accurate sizing. Slight scaling may still occur. Therefore, before drilling, it is recommended that all template dimensions are measured for accuracy.

LEFT BLANK INTENTIONALLY

GS 500/ 500XL Drill Template

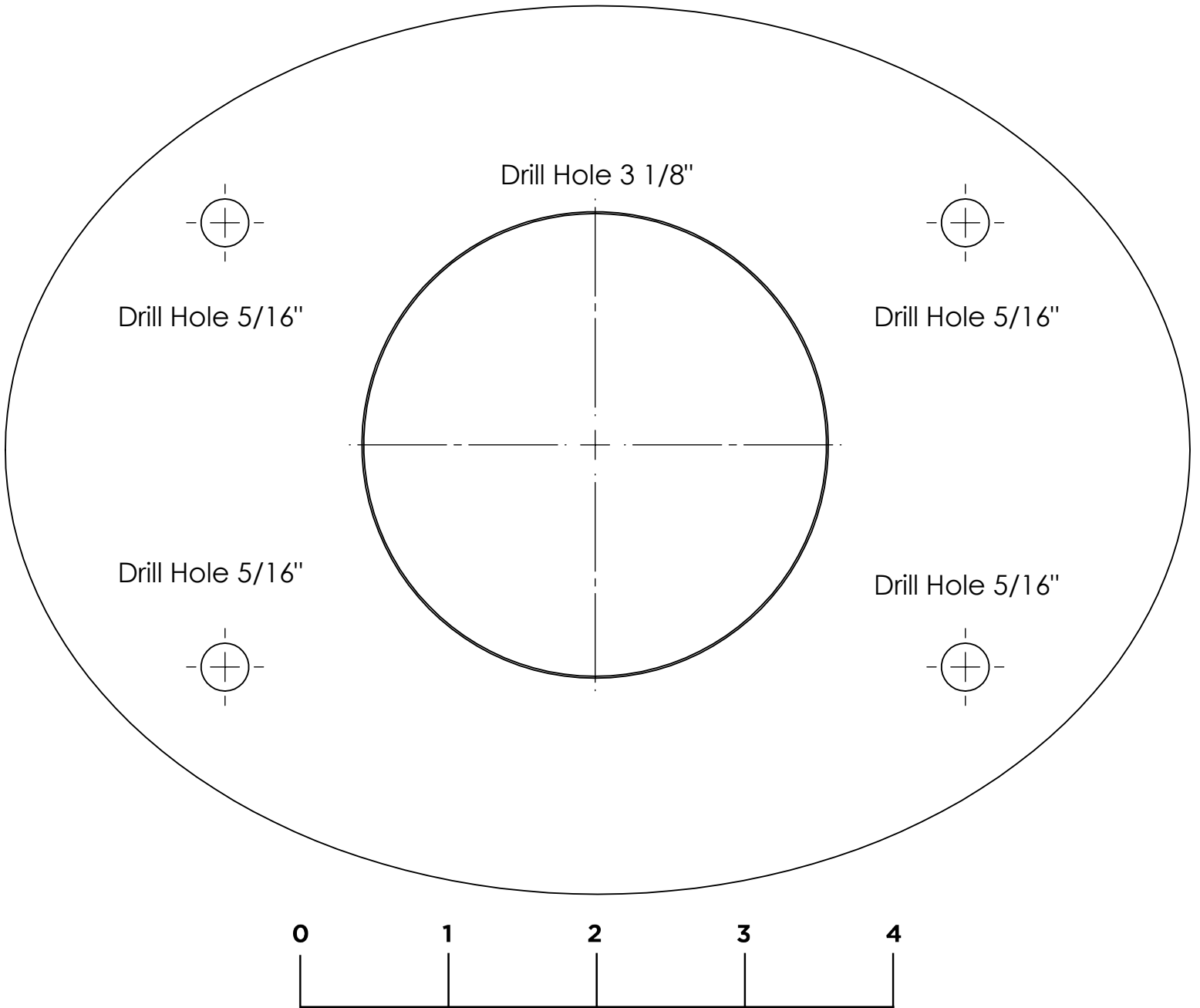

Please print at 100 percent for accurate sizing. Slight scaling may still occur. Therefore, before drilling, it is recommended that all template dimensions are measured for accuracy.

TACO[®]
MARINE